

QUICK SELECTION / Selezione veloce

input speed (n_1) = 1400 min⁻¹

Output Speed n_2 [min ⁻¹]	Ratio i	Motor power P_{1M} [kW]	Output torque M_{2M} [Nm]	Service factor f.s.	Nominal power P_{1R} [kW]	Nominal torque M_{2R} [Nm]	B5 motor flanges				B14 motor flanges				Output Shaft 	Ratios code
							-F	-G	-H	-I	-	-	-	-		
							100 112	132	160	180	-	-	-	-		
236	5.94	22	806	1.0	21.0	800	B							302915	standard ø50 ø45 On request	01
196	7.13	18.5	812	1.0	17.9	820	B							302913		02
163	8.58	18.5	977	1.0	17.3	950	B							302911		03
125	11.20	15	1033	1.0	13.9	1000	B							202915		04
104	13.43	15	1239	1.1	15.7	1350	B							202913		05
92	15.15	15	1397	1.0	14.4	1400	B							162915		06
87	16.17	15	1492	1.0	14.0	1450	B							202911		07
77	18.16	15	1675	0.9	13.3	1550	B							162913		08
71	19.70	11	1335	1.2	12.3	1550	B							132915		09
64	21.87	11	1482	1.1	11.4	1600	B							162911		10
59	23.62	11	1600	1.0	10.6	1600	B							132913		11
48.4	28.91	9	1671	1.0	8.6	1600	B							112913		12
40.2	34.81	7.5	1618	1.0	7.2	1600	B							112911		13
33.5	41.81	5.5	1436	1.1	6.0	1600	B							82913		14
27.8	50.34	5.5	1729	0.9	5.0	1600	B							82911		15

The dynamic efficiency is **0.94** for all ratios

- Motor Flanges Available**
Flange Motore Disponibili
- Supplied with Reduction Bushing**
Fornito con Bussola di Riduzione
- Available on Request without reduction bushing**
Disponibile a Richiesta senza Bussola di Riduzione
- Motor Flange Holes Position**
Posizione Fori Flangia Motore

EN Unit **X93C** is supplied without lubricant and equipped with a breather, level and drain plugs. User can add mineral oil keeping existing plugs. Should the user wish to fill it with synthetic oil, it is recommended to replace the existing plugs with a closed plug. See table 1 for lubrication and recommended quantity. In table 2 please see possible radial loads and axial loads on the gearbox.

I Il riduttore tipo **X93C** è fornito privo di lubrificazione con tappi di sfiato, livello e scarico olio. L'utente può immettere olio minerale mantenendo i tappi esistenti. Se immetterà olio sintetico, dovrà sostituire i tappi esistenti con altri tipo chiuso. Tab.1 per oli e quantità consigliati. Tab.2 carichi radiali e assiali applicabili al riduttore.

D Das Getriebe der Baugröße **X93C** wird ohne Schmiermittel geliefert. Es ist jedoch mit Einfüllschraube, Überdruckventil und Ablassschraube ausgerüstet. Das benötigte mineralische Öl kann über die Einfüllschraube eingefüllt werden. Sollte synthetisches Öl bevorzugt werden, so ist sind das eingebaute Überdruckventil durch eine geschlossenen Schraube zu ersetzen. In Tabelle 1 ist die Schmiermenge und das empfohlene Schmiermittel angegeben. In Tabelle 2 sind die zulässigen Radial - und Axialbelastungen des Getriebes aufgeführt.

F Le réducteur de type **X93C** est fourni sans lubrification et avec un bouchon de remplissage, de niveau et d'évacuation de l'huile. L'utilisateur peut y verser de l'huile minérale en conservant les bouchons existants. S'il y versera de l'huile synthétique, il devra substituer les bouchons existants avec d'autres bouchons de type fermé. Voir tableau 1 concernant les huiles et les quantités conseillées. Voir tableau 2 concernant les charges radiales et axiales applicables au réducteur.

E El reductor tamaño **X93C** se suministra sin lubricante, provisto de tapones de respiración, nivel y descarga de aceite. El usuario puede utilizar aceite mineral, manteniendo los tapones existentes. Si prefiere utilizar aceite sintético deberá sustituir los tapones existentes por tapones ciegos. La prerreducción se suministra con tapones ciegos, lubricado de por vida con aceite sintético. Ver tabla 1, para cantidades y aceites recomendados. En la tabla 2, se encuentran las cargas radiales y axiales admitidas por el reductor.

Standard supplied	For these mounting position specify in the order or add oil Per queste posizioni specificare in fase d'ordine o aggiungere olio					
B3	B6	B7	B8	V5	V6	V8
4.20 LT	3.60 LT	4.40 LT	5.10 LT	7.10 LT	5.00 LT	Ask
AGIP Blasias 460						

For all details on lubrication and plugs check our website [tab. 1](#)
Per maggiori dettagli su lubrificazione e tappi olio vedi il nostro sito web

RADIAL AND AXIAL LOADS

Output shaft
Albero di uscita

$F_{eq} = FR \cdot \frac{218}{X+168}$

$F_{eq} (N)$

n_2	FA	FR	n_2	FA	FR	n_2	FA	FR
300	1800	9000	140	2700	13500	70	3020	15100
250	2400	12000	120	2800	14000	40	3200	16000
200	2600	13000	85	2900	14500	15	3500	17500

Input shaft
Albero in entrata

n_1	FA	FR
1400	700	3500
900	840	4200
500	900	4500

tab. 2

PX93CC... Basic Gearbox
Riduttore base

Gearbox weight
peso riduttore **75.0 kg**

M. flanges	Kit code	øF	A
100/112B5	-	250	381
132B5	-	300	385
160/180B5	-	350	396

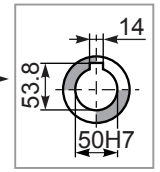
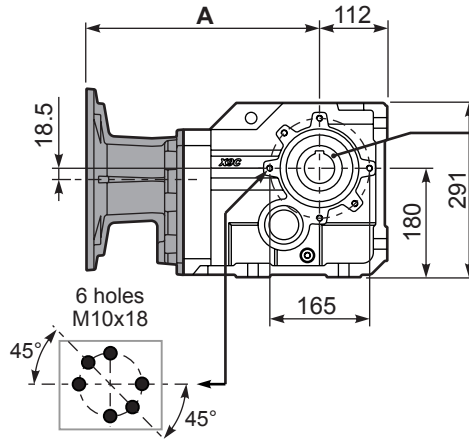
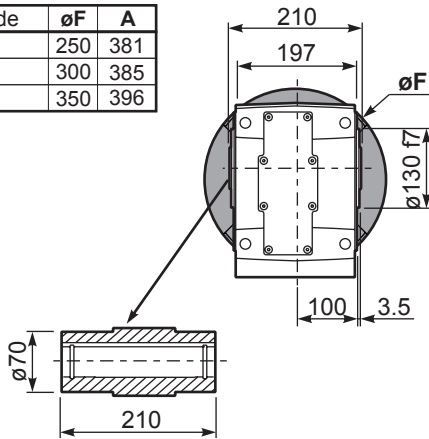

Standard
Hollow shaft

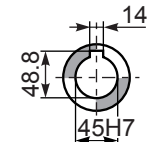

On request
A richiesta

Mounting holes position
Posizione fori di montaggio

PX93C...FB.. Feet
Piedini

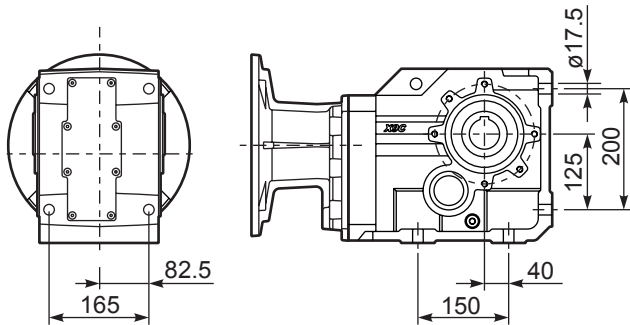

PX93C...-FC.. Output flange
Flangia uscita

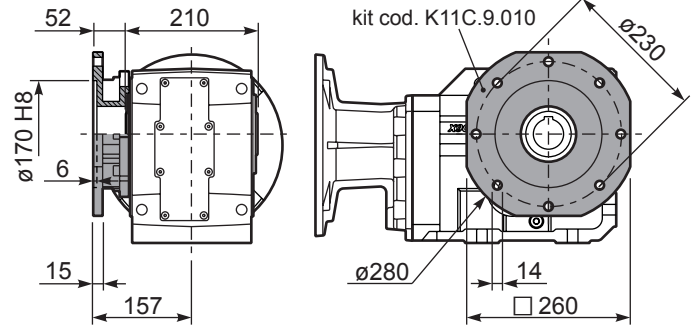

PX93C...-FL.. Output flange
Flangia uscita

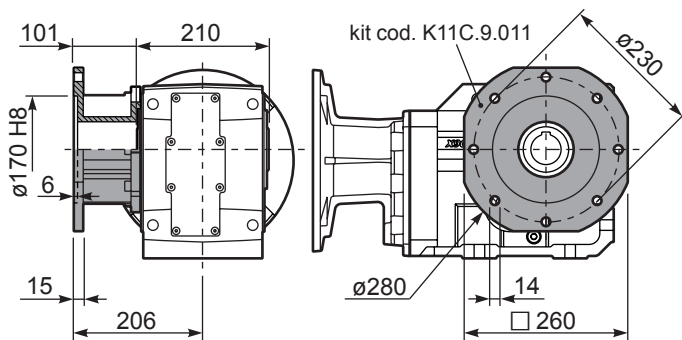

PX93C...BR.. Reaction Arm
Braccio di reazione

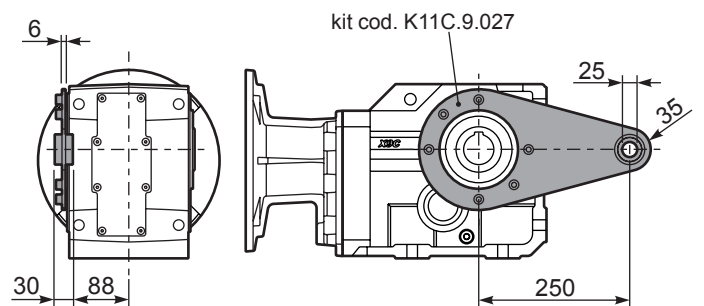

RX93C... Input shaft
Albero in entrata

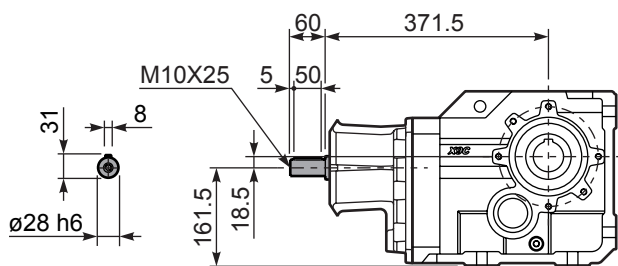

PX93CA... Single shaft
Albero lento semplice

PX93CB... Double shaft
Albero lento bisp.

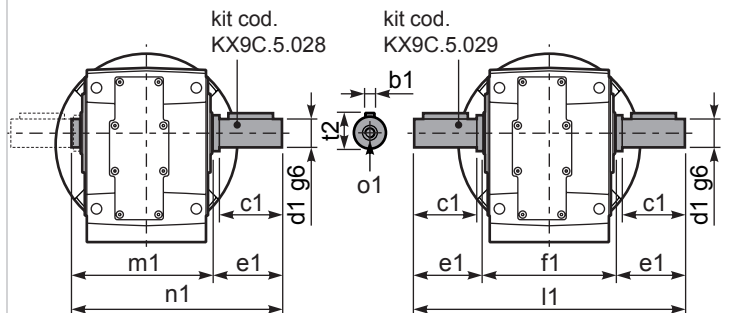

	b1	c1	d1	e1	f1	l1	m1	n1	t2	o1
Standard	14	100	50	105	210	420	218	323	53.5	M16
-	-	-	-	-	-	-	-	-	-	-