

QUICK SELECTION / Selezione veloce

input speed (n_1) = 1400 min⁻¹

Output Speed n_2 [min ⁻¹]	Ratio i	Motor power P_{1M} [kW]	Output torque M_{2M} [Nm]	Service factor f.s.	Nominal power P_{1R} [kW]	Nominal torque M_{2R} [Nm]	B5 motor flanges				B14 motor flanges				Output Shaft 	Ratios code
							-G	-H	-I	-L	-	-	-	-		
							132	160	180	200	-	-	-	-		
219	6.39	30	1180	1.1	31.7	1300								392914	01	
200	7.00	30	1292	1.1	31.2	1400								392913	02	
164	8.55	30	1578	1.0	27.4	1500								392911	03	
140	10.01	22	1357	1.2	24.9	1600								302914	04	
128	10.97	22	1486	1.1	24.2	1700								302913	05	
105	13.39	22	1815	1.2	24.5	2100								302911	06	
89	15.71	22	2130	1.0	21.8	2200								222914	07	
81	17.21	22	2333	1.0	20.8	2300								222913	08	
67	21.02	18.5	2394	1.0	17.8	2400								222911	09	
59	23.73	18.5	2703	1.0	17.1	2600								162914	10	
54	25.99	18.5	2960	0.9	16.8	2800								162913	11	
50	27.93	15	2576	1.1	16.2	2900								142914	12	
45.8	30.59	15	2822	1.0	14.8	2900								142913	13	
44.1	31.74	15	2928	1.0	14.2	2900								162911	14	
37.5	37.36	11	2532	1.1	12.1	2900								142911	15	
33.8	41.37	11	2804	1.0	10.9	2900								102914	16	
30.9	45.31	9	2618	1.1	10.0	2900								102913	17	
25.3	55.33	7.5	2573	1.2	8.5	3000								102911	18	

The dynamic efficiency is 0.94 for all ratios

Motor Flanges Available
Flange Motore Disponibili

B) Supplied with Reduction Bushing
Fornito con Bussola di Riduzione

B) Available on Request without reduction bushing
Disponibile a Richiesta senza Bussola di Riduzione

C) Motor Flange Holes Position
Posizione Fori Flangia Motore

EN Unit X103 is supplied without lubricant and equipped with a breather, level and drain plugs. User can add mineral oil keeping existing plugs. Should the user wish to fill it with synthetic oil, it is recommended to replace the existing plugs with a closed plug. See table 1 for lubrication and recommended quantity. In table 2 please see possible radial loads and axial loads on the gearbox.

I Il riduttore tipo X103 è fornito privo di lubrificazione con tappi di sfiato, livello e scarico olio. L'utente può immettere olio minerale mantenendo i tappi esistenti. Se immetterà olio sintetico, dovrà sostituire i tappi esistenti con altri tipo chiuso. Tab.1 per oli e quantità consigliati. Tab.2 carichi radiali e assiali applicabili al riduttore.

D Das Getriebe der Baugröße X103 wird ohne Schmiermittel geliefert. Es ist jedoch mit Einfüllschraube, Überdruckventil und Ablassschraube ausgerüstet. Das benötigte mineralische Öl kann über die Einfüllschraube eingefüllt werden. Sollte synthetisches Öl bevorzugt werden, so ist sind das eingebaute Überdruckventil durch eine geschlossenen Schraube zu ersetzen. In Tabelle 1 ist die Schmiermenge und das empfohlene Schmiermittel angegeben. In Tabelle 2 sind die zulässigen Radial - und Axialbelastungen des Getriebes aufgeführt.

F Le réducteur de type X103 est fourni sans lubrification et avec un bouchon de remplissage, de niveau et d'évacuation de l'huile. L'utilisateur peut y verser de l'huile minérale en conservant les bouchons existants. S'il y versera de l'huile synthétique, il devra substituer les bouchons existants avec d'autres bouchons de type fermé. Voir tableau 1 concernant les huiles et les quantités conseillées. Voir tableau 2 concernant les charges radiales et axiales applicables au réducteur.

E El reductor tamaño X103 se suministra sin lubricante, provisto de tapones de respiración, nivel y descarga de aceite. El usuario puede utilizar aceite mineral, manteniendo los tapones existentes. Si prefiere utilizar aceite sintético deberá sustituir los tapones existentes por tapones ciegos. La prerreducción se suministra con tapones ciegos, lubricado de por vida con aceite sintético. Ver tabla 1, para cantidades y aceites recomendados. En la tabla 2, se encuentran las cargas radiales y axiales admitidas por el reductor.

Standard supplied	For these mounting position specify in the order or add oil Per queste posizioni specificare in fase d'ordine o aggiungere olio					
11.50 LT	5.50 LT	10.50 LT	7.50 LT	13.50 LT	9.50 LT	Ask
AGIP Blasias 460						

For all details on lubrication and plugs check our website **tab. 1**
Per maggiori dettagli su lubrificazione e tappi olio vedi il nostro sito web

RADIAL AND AXIAL LOADS								
Output shaft Albero di uscita			Freq = $FR \cdot \frac{253}{X+193}$					
n_2	FA	FR	n_2	FA	FR	n_2	FA	FR
300	2000	10000	140	2800	14000	70	3500	17500
250	2500	12500	120	3000	15000	40	4200	21000
200	2700	13500	85	3200	16000	15	5400	27000
Input shaft Albero in entrata								
n_1	FA	FR						
1400	1120	5600						
900	1220	6100						
500	1300	6500						

tab. 2

PX103C... Basic Gearbox
Riduttore base

Gearbox weight **125 kg**
peso riduttore

M. flanges	Kit code	øF	A
132B5	KC1109052	300	486.5
160B5	KC1109053	350	511.5
180B5	KC1109053_B	350	511.5
200B5	KC1109054	400	511.5

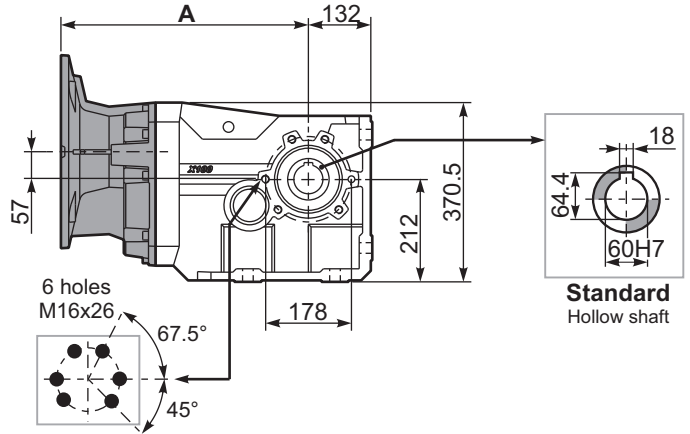
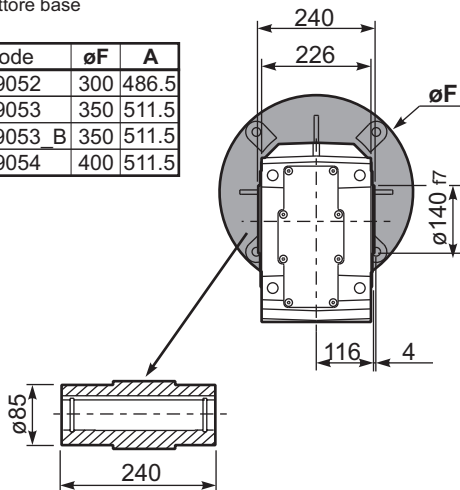

Mounting holes position
Posizione fori di montaggio

Standard
Hollow shaft

PX103...FB.. Feet
Piedini

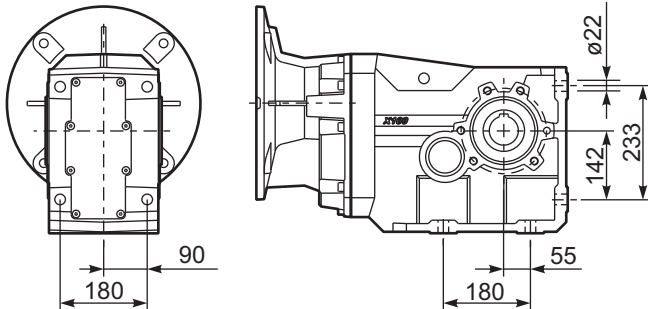

PX103...-F6.. Output flange
Flangia uscita

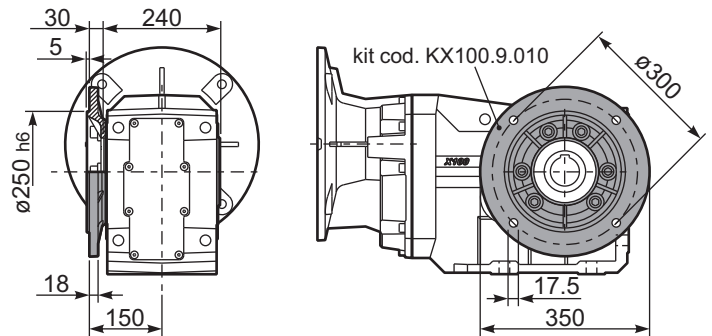

PX103...BR.. Reaction Arm
Braccio di reazione

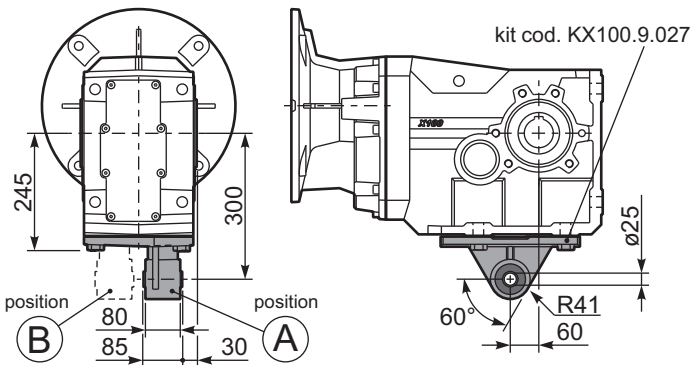

RX103... Input shaft
Albero in entrata

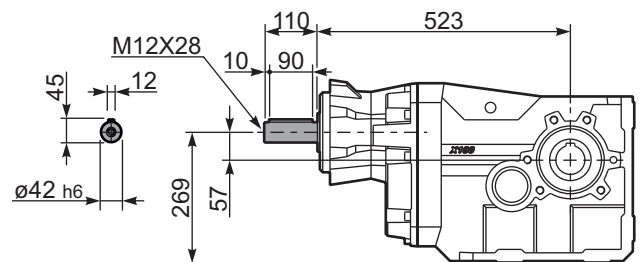

PX103A... Single shaft
Albero lento semplice

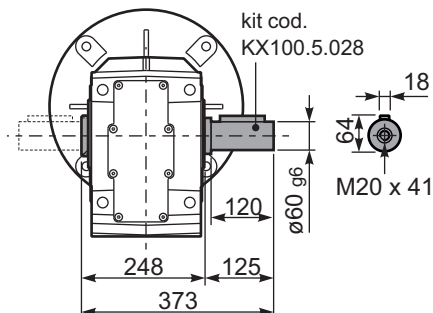

PX103B... Double shaft
Albero lento bisp.

