

QUICK SELECTION / Selezione veloce

input speed (n_1) = 1400 min⁻¹

Output Speed n_2 [min ⁻¹]	Ratio i	Motor power P_{1M} [kW]	Output torque M_{2M} [Nm]	Service factor f.s.	Nominal power P_{1R} [kW]	Nominal torque M_{2R} [Nm]	B5 motor flanges			B14 motor flanges			Output Shaft 	Ratios code
							-F	-G	-H	-	-	-		
							100 112	132	160	-	-	-		
28.8	48.57	15	4390	1.0	14.8	4500	B						30142911	01
20.5	68.43	11	4545	1.0	10.7	4600	B						20142914	02
18.7	74.95	11	4977	0.9	9.8	4600	B						20142913	03
15.1	92.53	7.5	4216	1.1	7.9	4600	B						16142914	04
13.8	101.33	7.5	4617	1.0	7.2	4600	B						16142913	05
11.6	120.33	5.5	4051	1.1	6.1	4600	B						13142914	06
11.3	123.75	5.5	4166	1.1	5.8	4500	B						16142911	07
10.6	131.78	5.5	4436	1.0	5.6	4600	B						13142913	08
9.5	147.28	5.5	4958	0.9	5.0	4600	B						11142914	09
8.7	161.30	4	3972	1.2	4.5	4600	B						11142913	10
7.1	196.98	3	3652	1.2	3.6	4500	B						11142911	11
6.6	212.99	3	3949	1.2	3.4	4600	B						8142914	12
6.0	233.26	3	4324	1.1	3.1	4600	B						8142913	13
4.9	284.86	2.2	3889	1.2	2.5	4500	B						8142911	14

The dynamic efficiency is **0.92** for all ratios

Motor Flanges Available
Flange Motore Disponibili

B) Supplied with Reduction Bushing
Fornito con Bussola di Riduzione

B) Available on Request without reduction bushing
Disponibile a Richiesta senza Bussola di Riduzione

C) Motor Flange Holes Position
Posizione Fori Flangia Motore

EN Unit **X114** is supplied without lubricant and equipped with a breather, level and drain plugs. User can add mineral oil keeping existing plugs. Should the user wish to fill it with synthetic oil, it is recommended to replace the existing plugs with a closed plug. See table 1 for lubrication and recommended quantity. In table 2 please see possible radial loads and axial loads on the gearbox.

I Il riduttore tipo **X114** è fornito privo di lubrificazione con tappi di sfiato, livello e scarico olio. L'utente può immettere olio minerale mantenendo i tappi esistenti. Se immetterà olio sintetico, dovrà sostituire i tappi esistenti con altri tipo chiuso. Tab.1 per oli e quantità consigliati. Tab.2 carichi radiali e assiali applicabili al riduttore.

D Das Getriebe der Baugröße **X114** wird ohne Schmiermittel geliefert. Es ist jedoch mit Einfüllschraube, Überdruckventil und Ablassschraube ausgerüstet. Das benötigte mineralische Öl kann über die Einfüllschraube eingefüllt werden. Sollte synthetisches Öl bevorzugt werden, so ist sind das eingebaute Überdruckventil durch eine geschlossenen Schraube zu ersetzen. In Tabelle 1 ist die Schmiermenge und das empfohlene Schmiermittel angegeben. In Tabelle 2 sind die zulässigen Radial - und Axialbelastungen des Getriebes aufgeführt.

F Le réducteur de type **X114** est fourni sans lubrification et avec un bouchon de remplissage, de niveau et d'évacuation de l'huile. L'utilisateur peut y verser de l'huile minérale en conservant les bouchons existants. S'il y versera de l'huile synthétique, il devra substituer les bouchons existants avec d'autres bouchons de type fermé. Voir tableau 1 concernant les huiles et les quantités conseillées. Voir tableau 2 concernant les charges radiales et axiales applicables au réducteur.

E El reductor tamaño **X114** se suministra sin lubricante, provisto de tapones de respiración, nivel y descarga de aceite. El usuario puede utilizar aceite mineral, manteniendo los tapones existentes. Si prefiere utilizar aceite sintético deberá sustituir los tapones existentes por tapones ciegos. La prerreducción se suministra con tapones ciegos, lubricado de por vida con aceite sintético. Ver tabla 1, para cantidades y aceites recomendados. En la tabla 2, se encuentran las cargas radiales y axiales admitidas por el reductor.

Standard supplied	For these mounting position specify in the order or add oil					
	Per queste posizioni specificare in fase d'ordine o aggiungere olio					
B3	B6	B7	B8	V5	V6	V8
14.50 LT	8.50 LT	16.50 LT	16.00 LT	23.00 LT	14.50 LT	Ask

AGIP Blasias 460

For all details on lubrication and plugs check our website
Per maggiori dettagli su lubrificazione e tappi olio vedi il nostro sito web

tab. 1

RADIAL AND AXIAL LOADS								
Output shaft Albero di uscita			$F_{eq} = FR \cdot \frac{325.5}{X+255.5}$					
n_2	FA	FR	n_2	FA	FR	n_2	FA	FR
300	2100	10500	140	3100	15500	70	4200	21000
250	2600	13000	120	3240	16200	40	5600	28000
200	3000	15000	85	3600	18000	15	8000	40000
Input shaft Albero in entrata								
n_1	FA	FR						
1400	700	3500						
900	840	4200						
500	900	4500						

tab. 2

PX114C...

Basic Gearbox
Riduttore base

Gearbox weight
peso riduttore **161 kg**

M. flanges	Kit code	øF	A
100/112B5	KC1109056	250	482.5
132B5	KC1109057	300	482.5
160B5	KC1109058	350	497.5

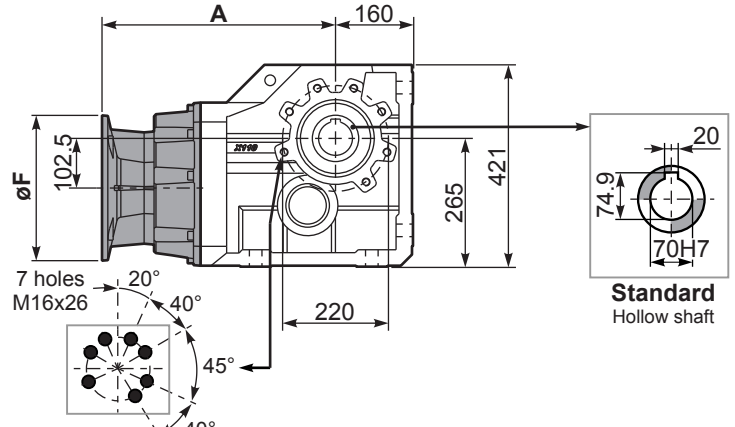
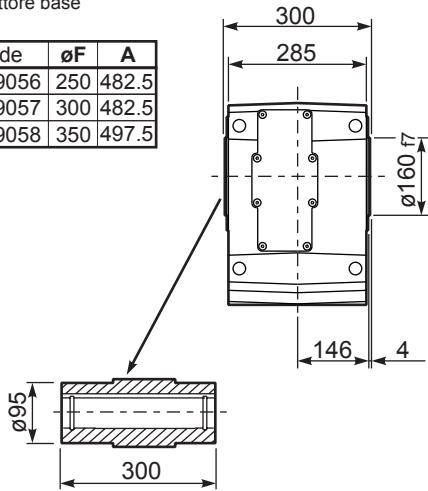

Mounting holes position
Posizione fori di montaggio

PX114...FB..

Feet
Piedini

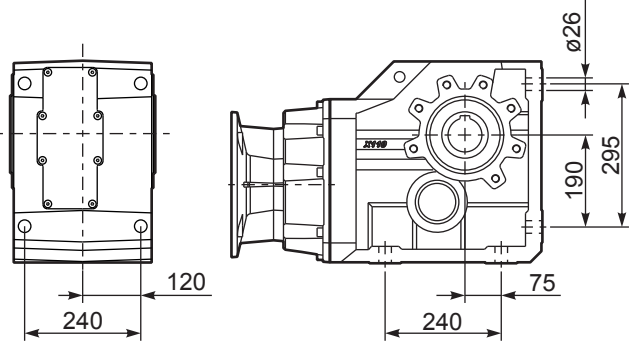

PX114...-F7..

Output flange
Flangia uscita

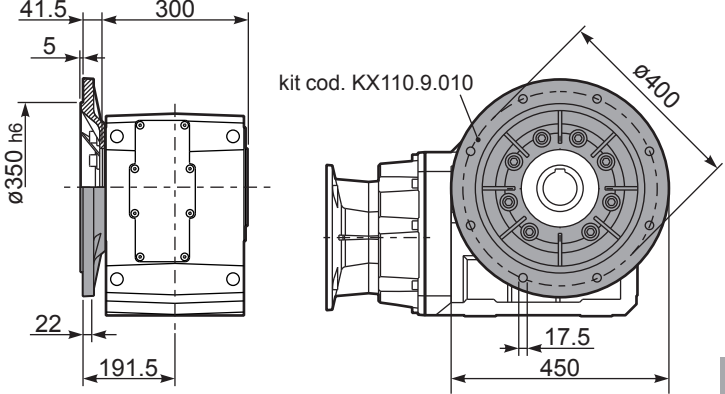

PX114...BR..

Reaction Arm
Braccio di reazione

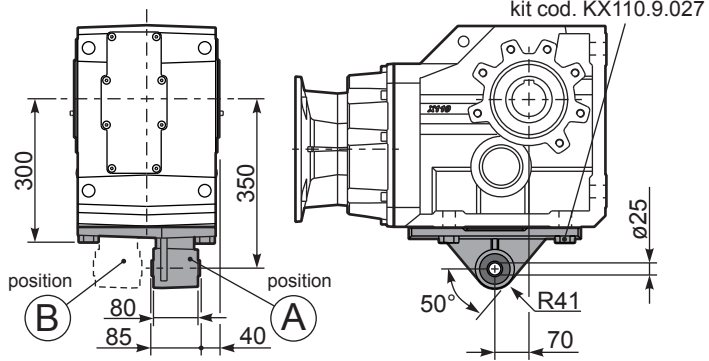

RX114...

Input shaft
Albero in entrata

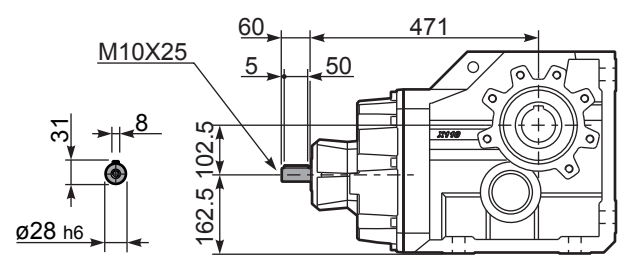

PX114A...

Single shaft
Albero lento semplice

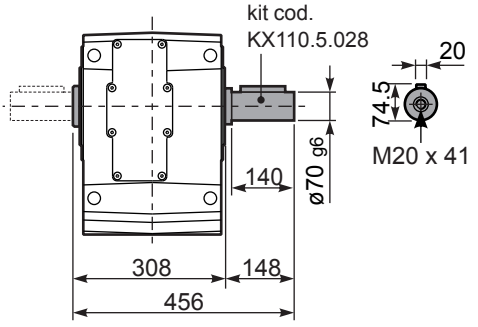

PX114B...

Double shaft
Albero lento bisp.

