



**QUICK SELECTION / Selezione veloce** The dynamic efficiency is **0.94** for all ratios **input speed (n<sub>1</sub>) = 1400 min<sup>-1</sup>**

Output Speed n <sub>2</sub> [min <sup>-1</sup> ]	Ratio i	Motor power P <sub>1M</sub> [kW]	Output torque M <sub>2M</sub> [Nm]	Service factor f.s.	Nominal power P <sub>1R</sub> [kW]	Nominal torque M <sub>2R</sub> [Nm]	Available B5 motor flanges		Available B14 motor flanges			Output Shaft 	Ratios code
							B	C	O	P	Q		
							63	71	56	63	71		
27.8	<b>50.35</b>	0.37	119	1.3	<b>0.46</b>	<b>150</b>			C	C		171311	01
25.4	<b>55.22</b>	0.37	131	1.1	<b>0.42</b>	<b>150</b>			C	C		17178	02
23.4	<b>59.92</b>	0.37	142	1.1	<b>0.39</b>	<b>150</b>			C	C		151311	03
21.3	<b>65.72</b>	0.37	156	1.0	<b>0.36</b>	<b>150</b>			C	C		15178	04
19.5	<b>71.78</b>	0.25	115	1.3	<b>0.33</b>	<b>150</b>			C	C		101711	05
17.6	<b>79.44</b>	0.25	127	1.2	<b>0.29</b>	<b>150</b>			C	C		13178	06
15.2	<b>92.08</b>	0.25	147	1.0	<b>0.25</b>	<b>150</b>			C	C		15138	07
14.7	<b>95.03</b>	0.25	152	1.0	<b>0.25</b>	<b>150</b>			C	C		91711	08
11.1	<b>126.55</b>	0.18	155	1.0	<b>0.20</b>	<b>160</b>			C	C		71711	09
10.5	<b>133.15</b>	0.18	163	1.0	<b>0.19</b>	<b>160</b>			C	C		91311	10
9.3	<b>150.18</b>	0.12	119	1.3	<b>0.17</b>	<b>160</b>			C	C		61711	11
7.9	<b>177.30</b>	0.12	140	1.1	<b>0.14</b>	<b>160</b>			C	C		71311	12
6.7	<b>210.42</b>	0.09	133	1.2	<b>0.12</b>	<b>160</b>			C	C		61311	13
6.1	<b>230.79</b>	0.09	146	1.1	<b>0.11</b>	<b>160</b>			C	C		6178	14
5.1	<b>272.47</b>	0.06	113	1.4	<b>0.09</b>	<b>160</b>			C	C		7138	15
4.3	<b>323.37</b>	0.06	134	1.2	<b>0.08</b>	<b>160</b>			C	C		6138	16

Motor Flanges Available Flange Motore Disponibili    
 B) Supplied with Reduction Bushing Fornito con Bussola di Riduzione    
 B) Available on Request without reduction bushing Disponibile a Richiesta senza Bussola di Riduzione    
 C) Motor Flange Holes Position Posizione Fori Flangia Motore

**EN** Unit **X43A** is supplied with synthetic oil for lifetime lubrication, no maintenance is necessary. See table 1 for lubrication and recommended quantity. In table 2 please see possible radial loads and axial loads on the gearbox.  
For complete documentation please visit our web site.

**I** Il riduttore **X43A** viene fornito completo di olio sintetico per la lubrificazione permanente e non necessita di alcuna manutenzione. Vedi tab.1 per oli e quantità consigliati. In tab.2 sono presenti i carichi radiali e assiali applicabili al riduttore.  
Per la documentazione completa consulta il nostro sito.

**D** Das Getriebe **X43A** ist mit synthetischem Öl gefüllt und ist lebensdauergeschmiert. In Tabelle 1 ist die Schmiermenge und das empfohlene Schmiermittel angegeben. In Tabelle 2 sind die zulässigen Radial - und Axialbelastungen des Getriebes aufgeführt. Die komplette Dokumentation, Wartungs - und Inbetriebnahmeanleitungen finden Sie unter.

**E** El reductor tamaño **X43A** se suministra, lubricado de por vida con aceite sintético y no requieren mantenimiento alguna. Ver tabla 1, para cantidades y aceites recomendados. En la tabla 2, se encuentran las cargas radiales y axiales admitidas por el reductor. Para documentación completa, consultar nuestra Web.

Standard supplied	For these mounting position specify in the order or add oil Per queste posizioni specificare in fase d'ordine o aggiungere olio					
B3	B6	B7	B8	V5	V6	V8
0.80 LT	0.80 LT	0.60 LT	0.80 LT	1.20 LT	0.70 LT	0.70 LT
AGIP Telium VSF 320			SHELL Omala S4 WE 320			

For all details on lubrication and plugs check our website **tab. 1**  
Per maggiori dettagli su lubrificazione e tappi olio vedi il nostro sito web

### RADIAL AND AXIAL LOADS

**Output shaft**  
Albero di uscita

$F_{eq} = F_R \cdot \frac{54}{X+28}$

n <sub>2</sub> [min <sup>-1</sup> ]	FA	FR	n <sub>2</sub> [min <sup>-1</sup> ]	FA	FR	n <sub>2</sub> [min <sup>-1</sup> ]	FA	FR
250	500	2500	75	800	4000	15	960	4800
150	600	3000	50	960	4800			
100	700	3500	25	960	4800			

**FR** On request taper roller bearings to increase radial loads.  
A richiesta cuscinetti a rulli conici per aumentare i carichi radiali.

**Input shaft**  
albero in entrata

n <sub>1</sub> [min <sup>-1</sup> ]	FA	FR
1400	140	700
900	160	800
600	190	950

**\*Strong axial loads in the DX direction are not allowed.**  
Non sono consentiti forti carichi assiali con direzione DX

**SELECT THIS TYPE AND THIS SPECIFIC SIZE ON THE WEB PAGES TO GET COMPLETE TECHNICAL DATA.**  
Selezionare tipo e gandezza specifica nel sito web per la documentazione completa.

**PX43A-C...** Basic Gearbox  
Riduttore base

Gearbox weight  
peso riduttore **7.93 kg**

M. flanges	Kit code	øF	A
<b>63B5</b>	K050.4.041	138	203
<b>71B5</b>	K050.4.042	160	201
<b>56B14</b>	KC40.4.049	80	202.5
<b>63B14</b>	K050.4.047	90	205
<b>71B14</b>	K050.4.045	105	202.5

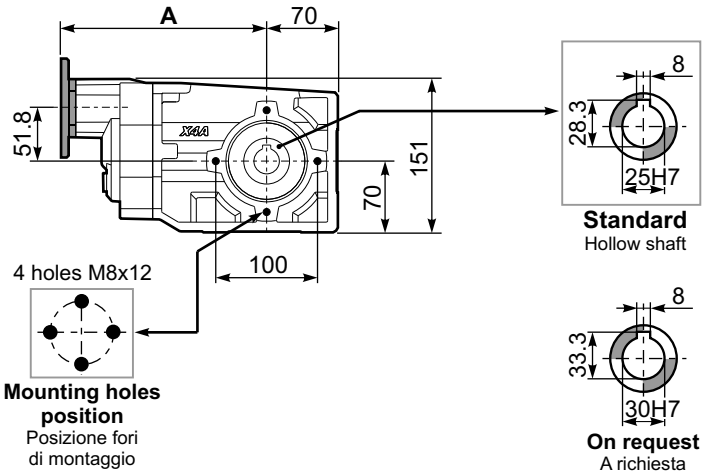
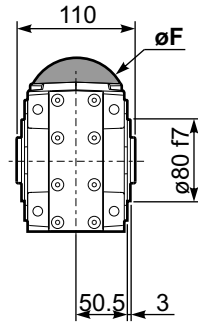

**PX43A-N..** Feet  
Piedini

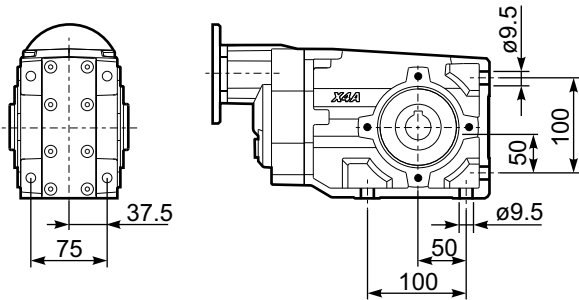

**PX43A-F2..** Output flange  
Flangia uscita

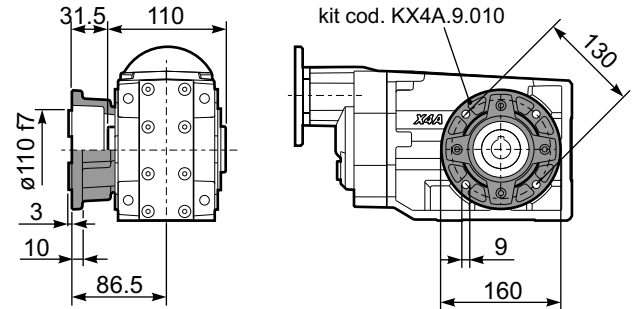

**PX43A-F3..** Output flange  
Flangia uscita

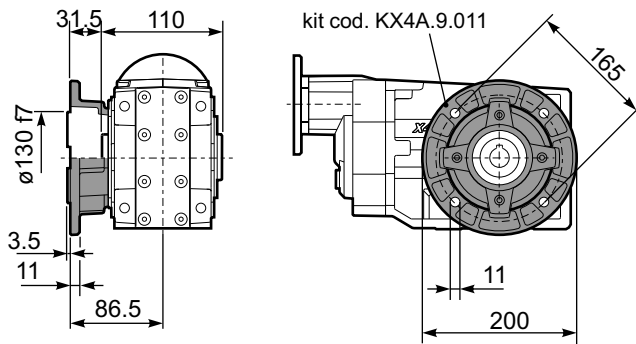

**PX43A-F4..** Output flange  
Flangia uscita

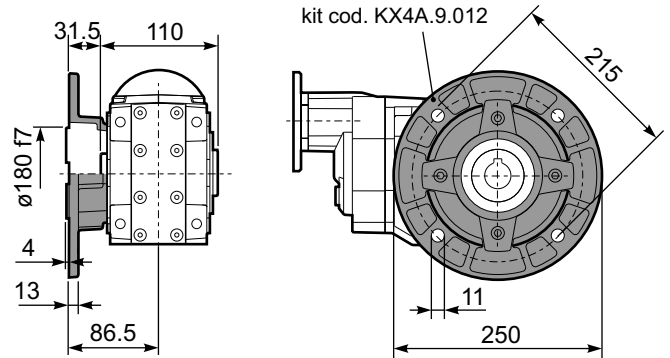

**RX43A...** Input shaft  
Albero in entrata

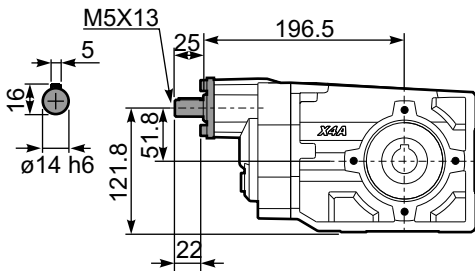

**PX43A-BR..** Reaction Arm  
Braccio di reazione

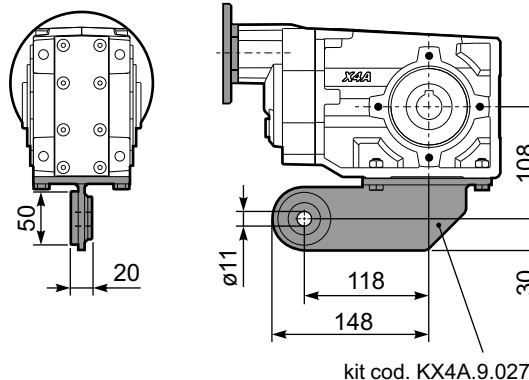

**PX43A..A..** Single output shaft  
Albero semplice in uscita

