



QUICK SELECTION / Selezione veloce The dynamic efficiency is **0.94** for all ratios **input speed (n₁) = 1400 min⁻¹**

Output Speed n ₂ [min ⁻¹]	Ratio i	Motor power P _{1M} [kW]	Output torque M _{2M} [Nm]	Service factor f.s.	Nominal power P _{1R} [kW]	Nominal torque M _{2R} [Nm]	Available B5 motor flanges		Available B14 motor flanges			Output Shaft 	Ratios code
							B	C	O	P	Q		
							63	71	56	63	71		
38.7	36.17	0.37	86	1.2	0.43	100			C	C		17179	01
31.7	44.21	0.37	105	1.0	0.35	100			C	C		19139	02
27.6	50.68	0.25	81	1.2	0.31	100			C	C		17139	03
25.3	55.36	0.25	89	1.1	0.28	100			C	C		17177	04
23.2	60.31	0.25	97	1.0	0.26	100			C	C		15139	05
21.3	65.88	0.25	105	0.9	0.24	100			C	C		15177	06
19.4	72.25	0.18	88	1.1	0.22	100			C	C		10179	07
17.6	79.64	0.18	97	1.0	0.20	100			C	C	standard	13177	08
15.2	92.31	0.18	113	0.9	0.17	100			C	C	ø20	15137	09
14.6	95.65	0.18	117	0.9	0.16	100			C	C		9179	10
13.8	101.23	0.12	80	1.2	0.15	100			C	C	ø25	10139	11
11.0	127.37	0.12	101	1.0	0.12	100			C	C	On request	7179	12
9.3	151.16	0.09	95	1.0	0.10	100			C	C		6179	13
7.8	178.46	0.09	113	0.9	0.09	100			C	C		7139	14
6.6	211.79	0.06	88	1.1	0.07	100			C	C		6139	15
6.1	231.37	0.06	96	1.0	0.07	100			C	C		6177	16
5.1	273.16	0.06	113	0.9	0.06	100			C	C		7137	17
4.3	324.18	0.06	134	0.7	0.05	100			C	C		6137	18

Motor Flanges Available Flange Motore Disponibili **B) Supplied with Reduction Bushing** Fornito con Bussola di Riduzione **B) Available on Request without reduction bushing** Disponibile a Richiesta senza Bussola di Riduzione **C) Motor Flange Holes Position** Posizione Fori Flangia Motore

EN Unit **X33S** is supplied with synthetic oil for lifetime lubrication, no maintenance is necessary. See table 1 for lubrication and recommended quantity. In table 2 please see possible radial loads and axial loads on the gearbox. For complete documentation please visit our web site.

I Il riduttore **X33S** viene fornito completo di olio sintetico per la lubrificazione permanente e non necessita di alcuna manutenzione. Vedi tab.1 per oli e quantità consigliati. In tab.2 sono presenti i carichi radiali e assiali applicabili al riduttore. Per la documentazione completa consulta il nostro sito.

D Das Getriebe **X33S** ist mit synthetischem Öl gefüllt und ist lebensdauergeschmiert. In Tabelle 1 ist die Schmiermenge und das empfohlene Schmiermittel angegeben. In Tabelle 2 sind die zulässigen Radial- und Axialbelastungen des Getriebes aufgeführt. Die komplette Dokumentation, Wartungs- und Inbetriebnahmeanleitungen finden Sie unter.

E El reductor tamaño **X33S** se suministra, lubricado de por vida con aceite sintético y no requieren mantenimiento alguna. Ver tabla 1, para cantidades y aceites recomendados. En la tabla 2, se encuentran las cargas radiales y axiales admitidas por el reductor. Para documentación completa, consultar nuestra Web.

Standard supplied	For these mounting position specify in the order or add oil Per queste posizioni specificare in fase d'ordine o aggiungere olio					
B3	B6	B7	B8	V5	V6	V8
0.70 LT	0.65 LT	0.40 LT	0.65 LT	0.95 LT	0.65 LT	0.45 LT
AGIP Telium VSF 320			SHELL Omala S4 WE 320			

For all details on lubrication and plugs check our website **tab. 1**
Per maggiori dettagli su lubrificazione e tappi olio vedi il nostro sito web

RADIAL AND AXIAL LOADS

Output shaft
Albero di uscita

$F_{eq} = F_R \cdot \frac{47.5}{X+28.5}$

n ₂ [min ⁻¹]	FA	FR	n ₂ [min ⁻¹]	FA	FR	n ₂ [min ⁻¹]	FA	FR
250	400	2000	75	560	2800	15	560	2800
150	450	2250	50	560	2800			
100	500	2500	25	560	2800			

FR On request taper roller bearings to increase radial loads.
A richiesta cuscinetti a rulli conici per aumentare i carichi radiali.

Input shaft
albero in entrata

n ₁ [min ⁻¹]	FA	FR
1400	140	700
900	160	800
600	190	950

*Strong axial loads in the DX direction are not allowed.
Non sono consentiti forti carichi assiali con direzione DX

tab. 2

SELECT THIS TYPE AND THIS SPECIFIC SIZE ON THE WEB PAGES TO GET COMPLETE TECHNICAL DATA.
Selezionare tipo e gandezza specifica nel sito web per la documentazione completa.

PX33S-C... Basic Gearbox
Riduttore base

Gearbox weight 6.55 kg
peso riduttore

M. flanges	Kit code	øF	A
63B5	K050.4.041	138	187.5
71B5	K050.4.042	160	185.5
56B14	KC40.4.049	80	187
63B14	K050.4.047	90	189.5
71B14	K050.4.045	105	187

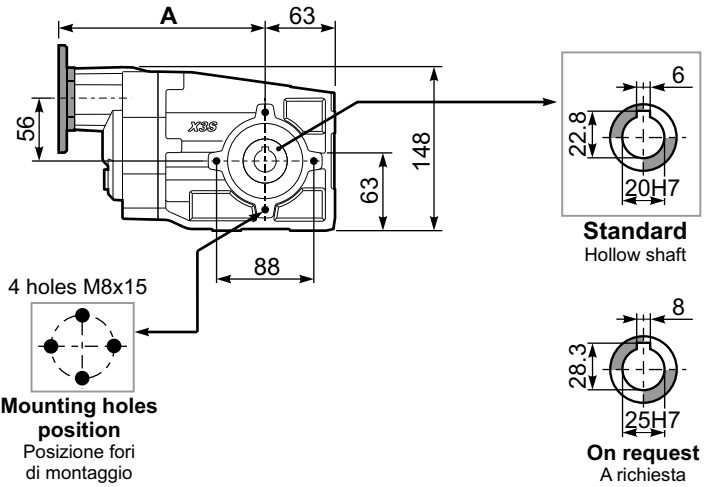
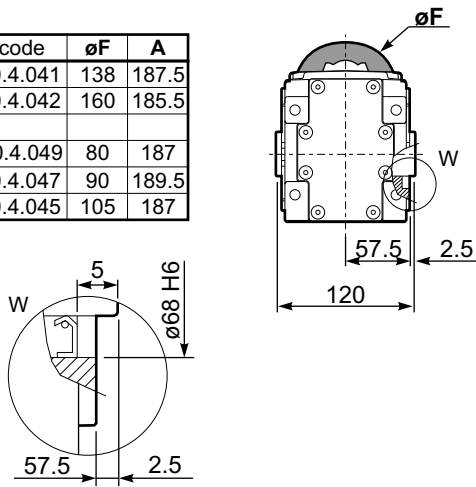

Mounting holes position
Posizione fori di montaggio

PX33S-N.. Feet
Piedi

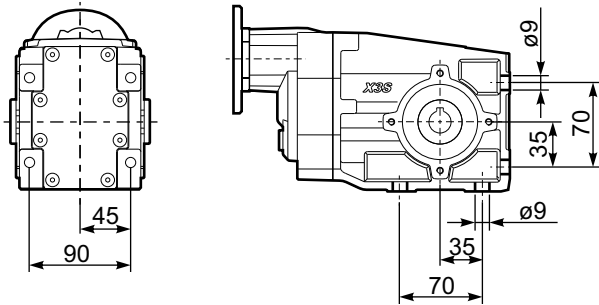

PX33S-F1.. Output flange
Flangia uscita

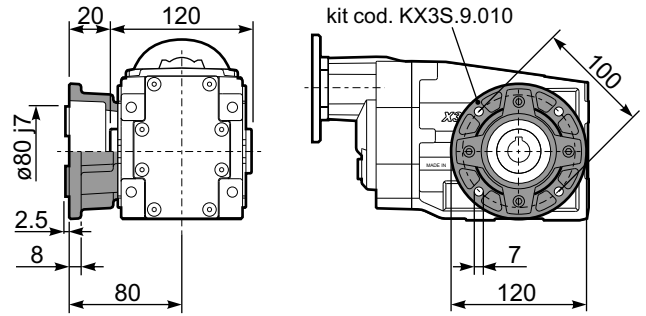

PX33S-F2.. Output flange
Flangia uscita

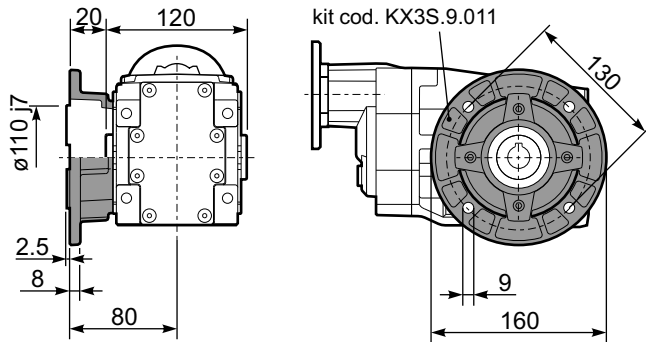

PX33S-BR.. Reaction Arm
Braccio di reazione

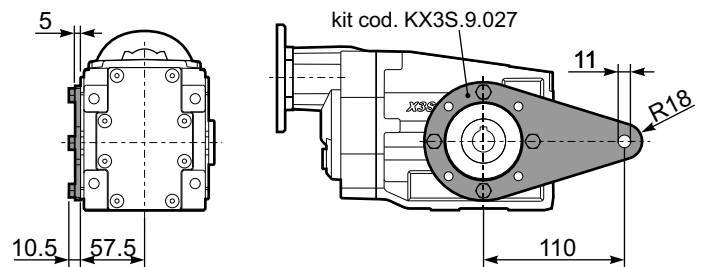

RX33S... Input shaft
Albero in entrata

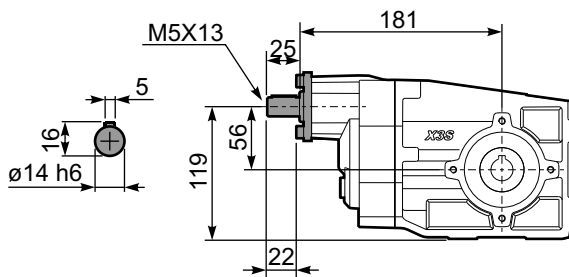

PX33S..A.. Single output shaft
Albero semplice in uscita

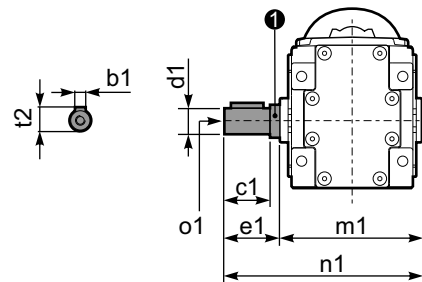

d1	b1	c1	e1	m1	n1	t2	o1	1 kit code
ø20 ^{-0.005/-0.020}	6	37.5	40	120	140	22.5	M8x20	KX2S.5.028
ø25 ^{-0.005/-0.020}	8	60	63.2	126.8	190	28	M8x20	K063.5.028