

QUICK SELECTION / Selezione veloce The dynamic efficiency is **0.96** for all ratios **input speed (n₁) = 1400 min⁻¹**

Output Speed n ₂ [min ⁻¹]	Ratio i	Motor power P _{1M} [kW]	Output torque M _{2M} [Nm]	Service factor f.s.	Nominal power P _{1R} [kW]	Nominal torque M _{2R} [Nm]	Available B5 motor flanges		Available B14 motor flanges			Output Shaft 	Ratios code
							B	C	O	P	Q		
							63	71	56	63	71		
289.7	4.83	0.37	12	2.6	0.95	30			C	C		289	01
189.2	7.40	0.37	18	1.7	0.62	30			C	C		287	02
146.2	9.58	0.37	23	1.7	0.64	40			C	C		199	03
127.5	10.98	0.37	27	1.7	0.63	45			C	C		179	04
107.1	13.07	0.37	32	1.4	0.53	45			C	C		159	05
95.5	14.66	0.37	36	1.3	0.47	45			C	C		197	06
88.6	15.79	0.37	38	1.2	0.44	45			C	C		139	07
83.3	16.81	0.37	41	1.1	0.41	45			C	C		177	08
70.0	20.00	0.37	48	1.0	0.37	48			C	C		157	09
63.8	21.93	0.37	53	0.9	0.35	50			C	C		109	10
57.9	24.18	0.25	40	1.3	0.32	50			C	C		137	11
48.2	29.04	0.25	47	1.1	0.26	50			C	C		99	12
41.7	33.57	0.18	42	1.2	0.23	50			C	C		107	13
36.2	38.67	0.18	48	1.0	0.20	50			C	C		79	14
31.5	44.44	0.18	56	0.9	0.17	50			C	C		97	15
23.7	59.18	0.12	48	1.0	0.13	50			C	C		77	16
19.9	70.24	0.09	45	1.1	0.11	50			C	C		67	17

Motor Flanges Available Flange Motore Disponibili
B) Supplied with Reduction Bushing Fornito con Bussola di Riduzione
B) Available on Request without reduction bushing Disponibile a Richiesta senza Bussola di Riduzione
C) Motor Flange Holes Position Posizione Fori Flangia Motore

EN Unit **X22S** is supplied with synthetic oil for lifetime lubrication, no maintenance is necessary. See table 1 for lubrication and recommended quantity. In table 2 please see possible radial loads and axial loads on the gearbox. For complete documentation please visit our web site.

I Il riduttore **X22S** viene fornito completo di olio sintetico per la lubrificazione permanente e non necessita di alcuna manutenzione. Vedi tab.1 per oli e quantità consigliati. In tab.2 sono presenti i carichi radiali e assiali applicabili al riduttore. Per la documentazione completa consulta il nostro sito.

D Das Getriebe **X22S** ist mit synthetischem Öl gefüllt und ist lebensdauergeschmiert. In Tabelle 1 ist die Schmiermenge und das empfohlene Schmiermittel angegeben. In Tabelle 2 sind die zulässigen Radial - und Axialbelastungen des Getriebes aufgeführt. Die komplette Dokumentation, Wartungs - und Inbetriebnahmeanleitungen finden Sie unter.

E El reductor tamaño **X22S** se suministra, lubricado de por vida con aceites sintético y no requieren mantenimiento alguna. Ver tabla 1, para cantidades y aceites recomendados. En la tabla 2, se encuentran las cargas radiales y axiales admitidas por el reductor. Para documentación completa, consultar nuestra Web.

Standard supplied	For these mounting position specify in the order or add oil Per queste posizioni specificare in fase d'ordine o aggiungere olio					
B3	B6	B7	B8	V5	V6	V8
0.25 LT	0.25 LT	0.25 LT	0.25 LT	0.43 LT	0.31 LT	0.25 LT
AGIP Telium VSF 320			SHELL Omala S4 WE 320			

For all details on lubrication and plugs check our website **tab. 1**
Per maggiori dettagli su lubrificazione e tappi olio vedi il nostro sito web

• RADIAL AND AXIAL LOADS

Output shaft
Albero di uscita

$F_{eq} = FR \cdot \frac{42}{X+23}$

n ₂ [min ⁻¹]	FA	FR	n ₂ [min ⁻¹]	FA	FR	n ₂ [min ⁻¹]	FA	FR
400	360	1800	100	440	2200	25	440	2200
250	380	1900	75	440	2200	15	440	2200
150	420	2100	50	440	2200			

FR On request taper roller bearings to increase radial loads.
A richiesta cuscinetti a rulli conici per aumentare i carichi radiali.

Input shaft
albero in entrata

n ₁ [min ⁻¹]	FA	FR
1400	140	700
900	160	800
600	190	950

*Strong axial loads in the DX direction are not allowed.
Non sono consentiti forti carichi assiali con direzione DX

tab. 2

SELECT THIS TYPE AND THIS SPECIFIC SIZE ON THE WEB PAGES TO GET COMPLETE TECHNICAL DATA.
Selezionare tipo e gandezza specifica nel sito web per la documentazione completa.

PX22S-C... Basic Gearbox
Riduttore base

Gearbox weight 3.70 kg
peso riduttore

M. flanges	Kit code	øF	A
63B5	K050.4.041	138	152.5
71B5	K050.4.042	160	150.5
56B14	KC40.4.049	80	152
63B14	K050.4.047	90	154.5
71B14	K050.4.045	105	152

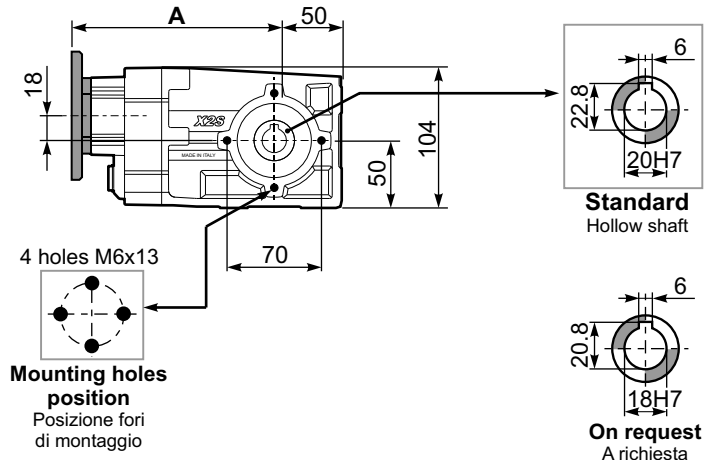
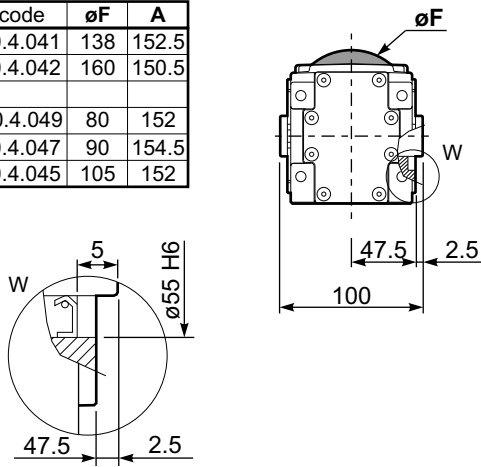

PX22S..-N.. Feet
Piedini

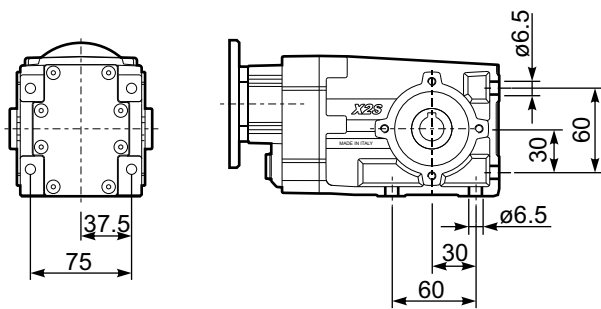

PX22S-F0.. Output flange
Flangia uscita

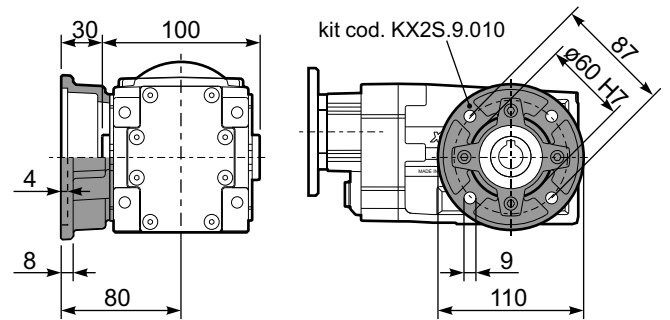

PX22S-F1.. Output flange
Flangia uscita

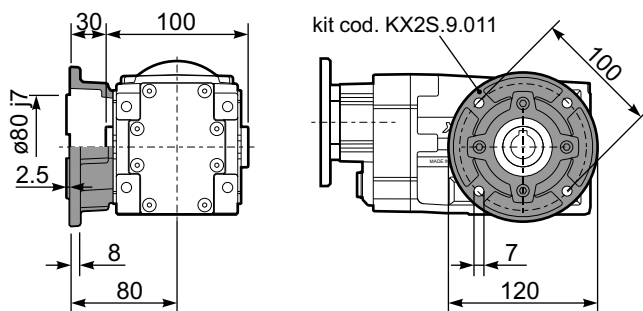

PX22S-BR.. Reaction Arm
Braccio di reazione

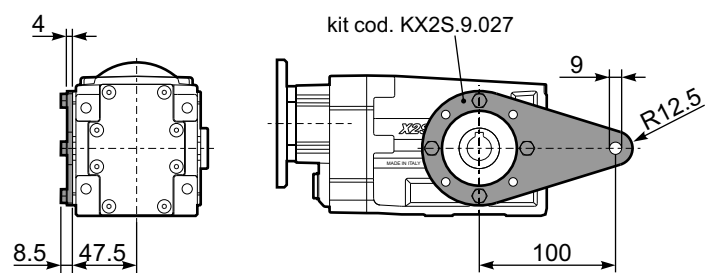

RX22S.. Input shaft
Albero in entrata

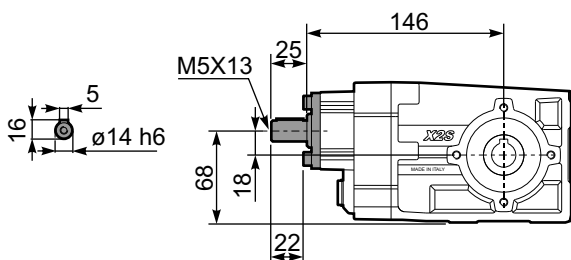

PX22S..A.. Single output shaft
Albero semplice in uscita

