



QUICK SELECTION / Selezione veloce

input speed (n_1) = 1400 min⁻¹

Output Speed n_2 [min ⁻¹]	Ratio i	Motor power P_{1M} [kW]	Output torque M_{2M} [Nm]	Service factor f.s.	Nominal power P_{1R} [kW]	Nominal torque M_{2R} [Nm]	Available B5 motor flanges				Available B14 motor flanges			Output Shaft \varnothing	Ratios code
							B	C	D	E	Q	R	T		
							63	71	80	90	71	80	90		
18.5	75.50	1.5	725	1.1	1.7	825	B				C	C		191318	01
16.2	86.47	1.5	830	1.1	1.6	900	B				C	C		191316	02
14.0	100.22	1.5	962	0.9	1.4	900	B				C	C		171316	03
12.0	116.56	1.1	817	1.1	1.2	900	B				C	C		171314	04
10.2	136.82	1.1	959	0.9	1.0	900	B				C	C		151314	05
9.1	153.05	0.75	736	1.1	0.83	810	B				C	C		190816	06
8.6	163.31	0.75	786	1.1	0.86	900	B				C	C		131314	07
7.9	178.01	0.75	856	1.1	0.79	900	B				C	C		190814	08
7.3	191.67	0.75	922	1.0	0.73	900	B				C	C		101316	09
6.8	206.32	0.75	992	0.9	0.68	900	B				C	C		170814	10
6.3	222.92	0.55	791	1.1	0.63	900	B				C	C		101314	11
5.8	242.18	0.55	859	1.0	0.58	900	B				C	C		150814	12
5.6	250.15	0.55	888	1.0	0.56	900	B				C	C		91316	13
4.8	289.08	0.55	1026	0.9	0.49	900	B				C	C		130814	14
4.2	330.31	0.37	783	1.1	0.41	860	B				C	C		71316	15
3.5	394.59	0.37	936	1.0	0.36	900	B				C	C		100814	16
2.7	514.99	0.25	824	1.1	0.27	900	B				C	C		90814	17
2.1	680.03	0.18	832	1.1	0.21	900	B				C	C		70814	18

The dynamic efficiency is **0.94** for all ratios

- Motor Flanges Available** Flange Motore Disponibili
- B) Supplied with Reduction Bushing** Fornito con Bussola di Riduzione
- B) Available on Request without reduction bushing** Disponibile a Richiesta senza Bussola di Riduzione
- C) Motor Flange Holes Position** Posizione Fori Flangia Motore

EN Unit **803C** is supplied without lubricant and equipped with a breather, level and drain plugs. User can add mineral oil keeping existing plugs. Should the user wish to fill it with synthetic oil, it is recommended to replace the existing plugs with a closed plug.
See table 1 for lubrication and recommended quantity. In table 2 please see possible radial loads and axial loads on the gearbox.
For complete documentation please visit our web site.

I Il riduttore tipo **803C** è fornito privo di lubrificazione con tappi di sfianto, livello e scarico olio. L'utente può immettere olio minerale mantenendo i tappi esistenti. Se immetterà olio sintetico, dovrà sostituire i tappi esistenti con altri tipo chiuso.
Tab.1 per oli e quantità consigliati.
Tab.2 carichi radiali e assiali applicabili al riduttore.
Per la documentazione completa consulta il nostro sito.

D Das Getriebe der Baugröße **803C** wird ohne Schmiermittel geliefert. Es ist jedoch mit Einfüllschraube, Überdruckventil und Ablassschraube ausgerüstet. Das benötigte mineralische Öl kann über die Einfüllschraube eingefüllt werden. Sollte synthetisches Öl bevorzugt werden, so ist sind das eingebaute Überdruckventil durch eine geschlossenen Schraube zu ersetzen.
In Tabelle 1 ist die Schmiermenge und das empfohlene Schmiermittel angegeben
In Tabelle 2 sind die zulässigen Radial - und Axialbelastungen des Getriebes aufgeführt.
Die komplette Dokumentation, Wartungs - und Inbetriebnahmeanleitungen finden Sie unter.

E El reductor tamaño **803C** se suministra sin lubricante, provisto de tapones de respiración, nivel y descarga de aceite. El usuario puede utilizar aceite mineral, manteniendo los tapones existentes. Si prefiere utilizar aceite sintético deberá sustituir los tapones existentes por tapones ciegos. La prerreducción se suministra con tapones ciegos, lubricado de por vida con aceite sintético.
Ver tabla 1, para cantidades y aceites recomendados.
En la tabla 2, se encuentran las cargas radiales y axiales admitidas por el reductor.
Para documentación completa, consultar nuestra Web.

B3	B6	B7	B8	V5	V6	V8
3.30 LT	1.90 LT	1.90 LT	1.55 LT	3.40 LT	2.30 LT	Ask
AGIP Blasias 460						

For all details on lubrication and plugs check our website **tab. 1**
Per maggiori dettagli su lubrificazione e tappi olio vedi il nostro sito web

RADIAL AND AXIAL LOADS

Output shaft
Albero di uscita

$F_{eq} = FR \cdot \frac{80.5}{X+40.5}$

n_2	FA	FR	n_2	FA	FR	n_2	FA	FR
300	1200	6000	140	1600	8000	70	2200	11000
250	1400	7000	120	1800	9000	40	2600	13000
200	1500	7500	85	2000	10000	15	3000	15000

On request reinforced bearings to increase loads.
A richiesta cuscinetti rinforzati per aumentare i carichi.

Input shaft
Albero di entrata

n_1	FA	FR
1400	400	2000
900	440	2200
500	440	2200

tab. 2

SELECT THIS TYPE AND THIS SPECIFIC SIZE ON THE WEB PAGES TO GET COMPLETE TECHNICAL DATA.
Selezionare tipo e gandezza specifica nel sito web per la documentazione completa.

P803C**S7** ... With feet
Con piedini

Gearbox weight **39.5 kg**
peso riduttore With feet **43.5 kg**

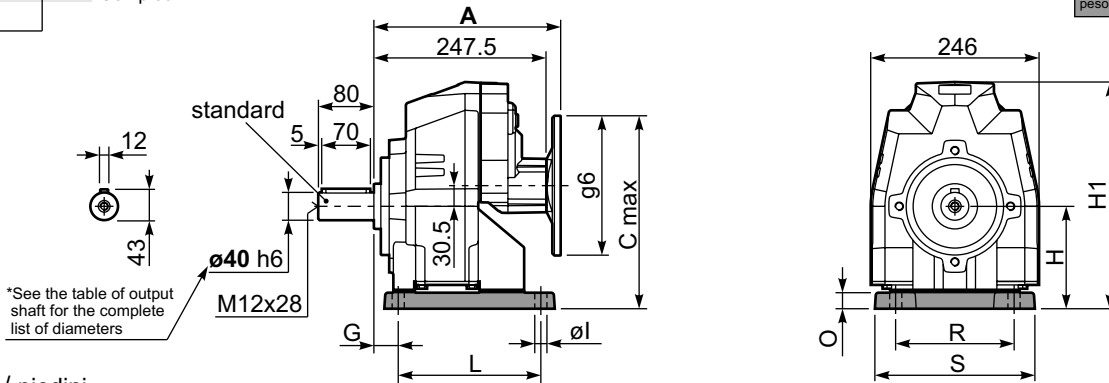

Feet / piedini

Feet Code	Market reference	G	H	R	L	S	H1	O	øl	B5 max. Flange	kit code
B5	512/3	25	155	225	156	270	333.5	30	18	-	KC80.9.022
S7	77	35	140	170	205	230	318.5	18	17.5	-	KC80.9.024
H6	026/263	40	175	215	215	265	353.5	30	16	-	KC80.9.023
-	-	-	-	-	-	-	-	-	-	-	-
-	-	-	-	-	-	-	-	-	-	-	-

P803C-**F** ... Output flanges
flange di uscita

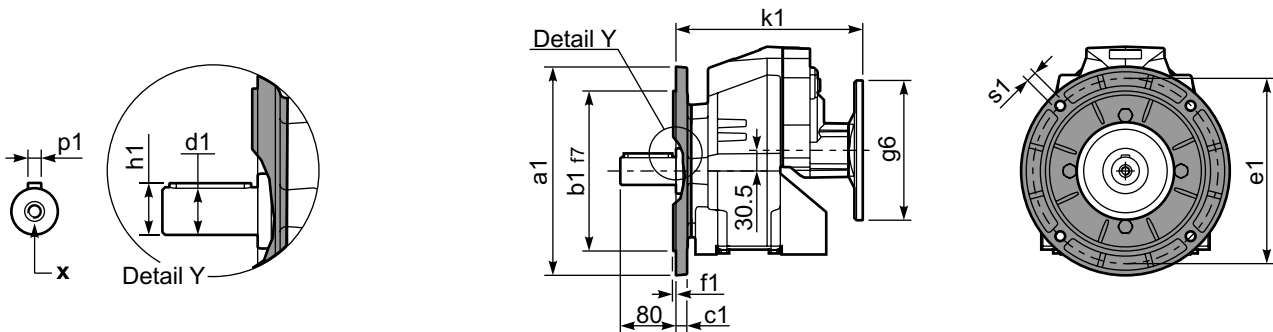

*Available output shaft / Albero di uscita

	Shaft - d1	p1	h1	x
Standard	ø 40x80	12	43	M12x28
On request A richiesta	ø 50x100	14	53.5	M16x36
-	-	-	-	-

Available output flanges / flange di uscita

a1 ø	b1	c1	e1	f1	s1	kit code
250	180	13	215	4	14	KC80.9.013
300	230	16	265	4	14	KC80.9.014
-	-	-	-	-	-	-

With flange and feet only on request. Ask for compatibility

P803C-**N**... Basic gearbox
Riduttore base

R803C-**N**... Input Shaft
Albero in entrata

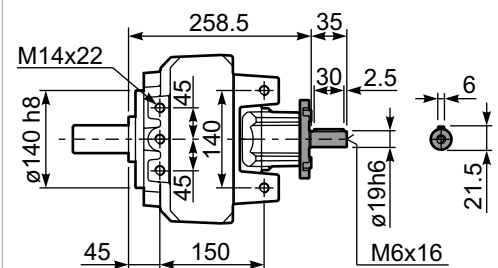
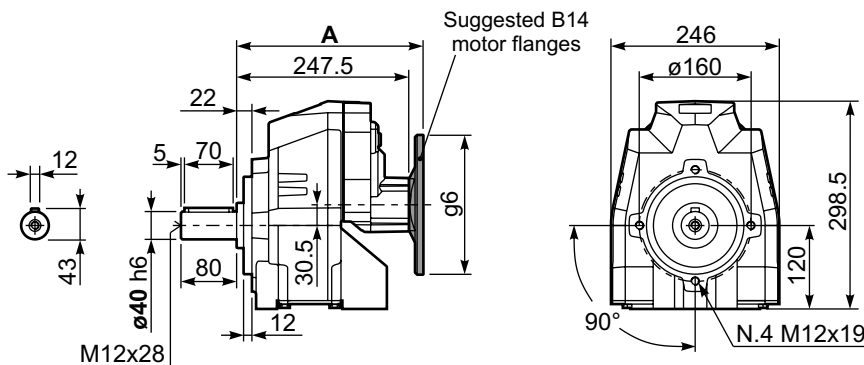

B5 Motor Flanges	A	C _{max}	g6	k1	kit code
63 B5	268	275.5	140	268	K063.4.041
71 B5	266	285.5	160	266	K063.4.042
80/90 B5	268	305.5	200	268	K063.4.043

B14 Motor Flanges	A	C _{max}	g6	k1	kit code
71 B14	266	258	105	266	K063.4.047
80 B14	267	265.5	120	267	K063.4.046
90 B14	268	275.5	140	268	K063.4.041