

QUICK SELECTION / Selezione veloce

input speed (n_1) = 1400 min⁻¹

Output Speed n_2 [min ⁻¹]	Ratio i	Motor power P_{1M} [kW]	Output torque M_{2M} [Nm]	Service factor f.s.	Nominal power P_{1R} [kW]	Nominal torque M_{2R} [Nm]	Available B5 motor flanges				B14 motor flanges			Output Shaft 	Ratios code
							-F	-G	-H	-I	-	-	-		
							100 112	132	160	180	-	-	-		
38.8	36.11	18.5	4113	1.1	19.4	4500	B						301411	01	
27.5	50.89	15	4694	1.0	14.1	4600	B						201414	02	
25.1	55.73	11	3777	1.2	12.9	4600	B						201413	03	
20.3	68.80	11	4662	1.0	10.4	4600	B						161414	04	
18.6	75.35	9	4354	1.1	9.5	4600	B						161413	05	
15.6	89.47	7.5	4160	1.1	8.0	4600	B						131414	06	
15.2	92.02	7.5	4278	1.1	7.6	4500	B						161411	07	
14.3	97.99	7.5	4556	1.0	7.3	4600	B						131413	08	
12.8	109.52	5.5	3762	1.2	6.6	4600	B						111414	09	
11.7	119.94	5.5	4120	1.1	6.0	4600	B						111413	10	
9.6	146.47	4	3681	1.2	4.8	4500	B						111411	11	
8.8	158.37	4	3980	1.2	4.5	4600	B						81414	12	
8.1	173.45	4	4359	1.1	4.1	4600	B						81413	13	
6.6	211.82	3	4007	1.1	3.3	4500	B						81411	14	

The dynamic efficiency is **0.94** for all ratios

Motor Flanges Available
Flange Motore Disponibili

B) Supplied with Reduction Bushing
Fornito con Bussola di Riduzione

B) Available on Request without reduction bushing
Disponibile a Richiesta senza Bussola di Riduzione

C) Motor Flange Holes Position
Posizione Fori Flangia Motore

EN Unit 1103 is supplied without lubricant and equipped with a breather, level and drain plugs. User can add mineral oil keeping existing plugs. Should the user wish to fill it with synthetic oil, it is recommended to replace the existing plugs with a closed plug.
See table 1 for lubrication and recommended quantity. In table 2 please see possible radial loads and axial loads on the gearbox.

I Il riduttore tipo 1103 è fornito privo di lubrificazione con tappi di sfiato, livello e scarico olio. L'utente può immettere olio minerale mantenendo i tappi esistenti. Se immetterà olio sintetico, dovrà sostituire i tappi esistenti con altri tipo chiuso.
Tab.1 per oli e quantità consigliati.
Tab.2 carichi radiali e assiali applicabili al riduttore.

D Das Getriebe der Baugröße 1103 wird ohne Schmiermittel geliefert. Es ist jedoch mit Einfüllschraube, Überdruckventil und Ablassschraube ausgerüstet. Das benötigte mineralische Öl kann über die Einfüllschraube eingefüllt werden. Sollte synthetisches Öl bevorzugt werden, so ist sind das eingebaute Überdruckventil durch eine geschlossenen Schraube zu ersetzen.
In Tabelle 1 ist die Schmiermenge und das empfohlene Schmiermittel angegeben
In Tabelle 2 sind die zulässigen Radial - und Axialbelastungen des Getriebes aufgeführt.

F Le réducteur de type 1103 est fourni sans lubrification et avec un bouchon de remplissage, de niveau et d'évacuation de l'huile. L'utilisateur peut y verser de l'huile minérale en conservant les bouchons existants. S'il y versera de l'huile synthétique, il devra substituer les bouchons existants avec d'autres bouchons de type fermé.
Voir tableau 1 concernant les huiles et les quantités conseillées.
Voir tableau 2 concernant les charges radiales et axiales applicables au réducteur

E El reductor tamaño 1103 se suministra sin lubricante, provisto de tapones de respiración, nivel y descarga de aceite. El usuario puede utilizar aceite mineral, manteniendo los tapones existentes. Si prefiere utilizar aceite sintético deberá sustituir los tapones existentes por tapones ciegos. La prerreducción se suministra con tapones ciegos, lubricado de por vida con aceite sintético. Ver tabla 1, para cantidades y aceites recomendados. En la tabla 2, se encuentran las cargas radiales y axiales admitidas por el reductor.

B3	B6	B7	B8	V5	V6	V8
7.00 LT	13.00 LT	8.00 LT	9.00 LT	16.00 LT	13.50 LT	Ask

AGIP Blasia 460

For all details on lubrication and plugs check our website [tab. 1](#)
Per maggiori dettagli su lubrificazione e tappi olio vedi il nostro sito web

RADIAL AND AXIAL LOADS

Output shaft
Albero di uscita

$F_{eq} = F_R \cdot \frac{138}{X+68}$

F_R (N)
 F_A (N)

F_{eq} (N)

n_2	FA	FR	n_2	FA	FR	n_2	FA	FR
300	2600	13000	140	3300	16500	70	4300	21500
250	2700	13500	120	3500	17500	40	5000	25000
200	3000	15000	85	3900	19500	15	5900	29500

Input shaft
Albero in entrata

F_R (N)
 F_A (N)

n_1	FA	FR
1400	700	3500
900	840	4200
500	900	4500

tab. 2

P1103**S0**... With foot
Con piedino

Gearbox weight
peso riduttore **156 kg**

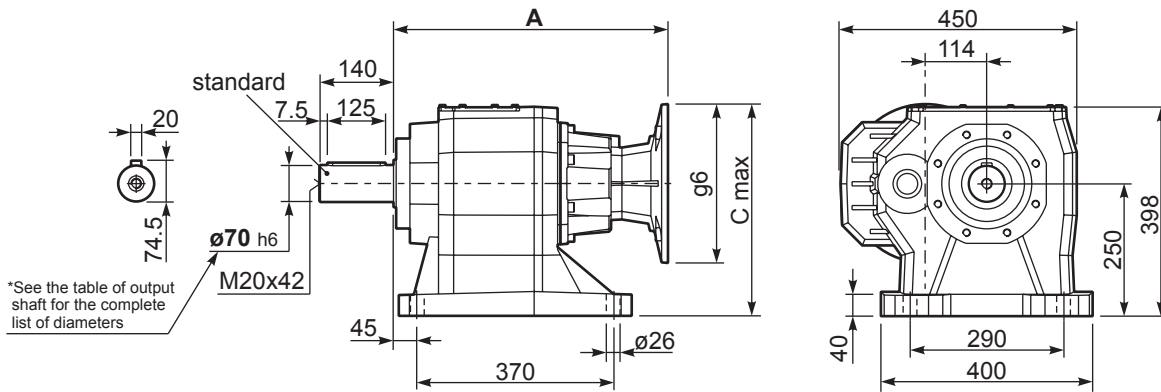

P1103-**F**... Output flanges
flange di uscita

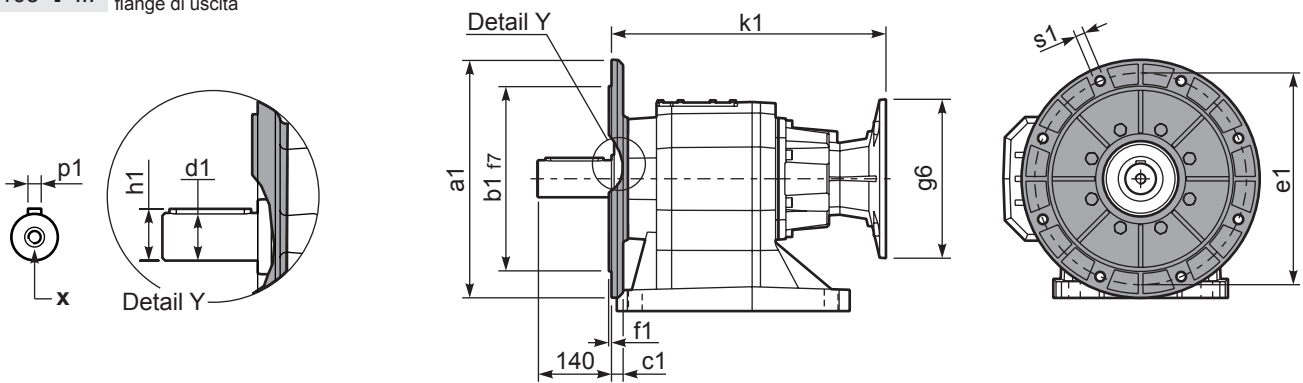

*Available output shaft / Albero di uscita

	Shaft - d1	p1	h1	x
Standard	ø 70x140	20	74.5	M20x42
On request A richiesta	-	-	-	-

Available output flanges / flange di uscita

a1 ø	b1	c1	e1	f1	s1	kit code
350	250	21	300	5	18	KC110.9.015
450	350	22	400	5	18	KC110.9.016
-	-	-	-	-	-	-

All flanges are compatible with the foot

P1103**S0**... Basic gearbox
Riduttore base

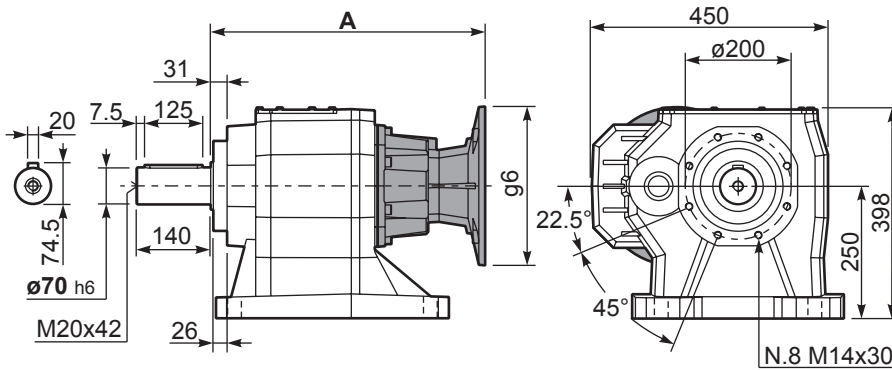

B5 Motor Flanges	A	C _{max}	g6	k1	kit code
100/112 B5	518.5	375	250	518.5	KC1109056
132 B5	518.5	400	300	518.5	KC1109057
160 B5	533.5	425	350	533.5	KC1109058
180 B5	533.5	425	350	533.5	KC1109058_B

R1103**S0**... Input Shaft
Albero in entrata

