



QUICK SELECTION / Selezione veloce

input speed (n_1) = 1400 min⁻¹

Output Speed n_2 [min ⁻¹]	Ratio i	Motor power P_{1M} [kW]	Output torque M_{2M} [Nm]	Service factor $f.s.$	Nominal power P_{1R} [kW]	Nominal torque M_{2R} [Nm]	B5 motor flanges				B14 motor flanges				Output Shaft 	Ratios code
							-F	-G	-H	-I	-	-	-	-		
							100 112	132	160	180	-	-	-	-		
234	5.98	22	827	1.2	25.5	1000	B							3015	01	
197	7.10	22	982	1.2	25.3	1175	B							3013	02	
162	8.63	22	1193	1.1	23.9	1350	B							3011	03	
124	11.27	18.5	1310	1.1	20.3	1500	B							2015	04	
105	13.38	18.5	1555	1.1	19.4	1700	B							2013	05	
92	15.24	18.5	1771	1.1	19.0	1900	B							1615	06	
86	16.26	18.5	1889	1.1	19.7	2100	B							2011	07	
77	18.09	18.5	2102	1.0	17.7	2100	B							1613	08	
71	19.82	15	1865	1.1	15.9	2060	B							1315	09	
64	21.98	15	2069	1.0	14.6	2100	B							1611	10	
60	23.53	15	2214	0.9	13.6	2100	B							1313	11	
58	24.25	11	1677	1.2	12.2	1940	B							1115	12	
48.6	28.80	11	1991	1.1	11.1	2100	B							1113	13	
40.0	34.99	9	2063	1.0	9.2	2100	B							1111	14	
33.6	41.64	7.5	1976	1.0	7.2	1960	B							813	15	
27.7	50.60	5.5	1774	1.2	6.3	2100	B							811	16	

The dynamic efficiency is **0.96** for all ratios

Motor Flanges Available Flange Motore Disponibili
 B) Supplied with Reduction Bushing Fornito con Bussola di Riduzione
 B) Available on Request without reduction bushing Disponibile a Richiesta senza Bussola di Riduzione
 C) Motor Flange Holes Position Posizione Fori Flangia Motore

EN Unit **902C** is supplied without lubricant and equipped with a breather, level and drain plugs. User can add mineral oil keeping existing plugs. Should the user wish to fill it with synthetic oil, it is recommended to replace the existing plugs with a closed plug. See table 1 for lubrication and recommended quantity. In table 2 please see possible radial loads and axial loads on the gearbox.

I Il riduttore tipo **902C** è fornito privo di lubrificazione con tappi di sfiato, livello e scarico olio. L'utente può immettere olio minerale mantenendo i tappi esistenti. Se immetterà olio sintetico, dovrà sostituire i tappi esistenti con altri tipo chiuso. Tab.1 per oli e quantità consigliati. Tab.2 carichi radiali e assiali applicabili al riduttore.

D Das Getriebe der Baugröße **902C** wird ohne Schmiermittel geliefert. Es ist jedoch mit Einfüllschraube, Überdruckventil und Ablassschraube ausgerüstet. Das benötigte mineralische Öl kann über die Einfüllschraube eingefüllt werden. Sollte synthetisches Öl bevorzugt werden, so ist sind das eingebaute Überdruckventil durch eine geschlossenen Schraube zu ersetzen. In Tabelle 1 ist die Schmiermenge und das empfohlene Schmiermittel angegeben. In Tabelle 2 sind die zulässigen Radial - und Axialbelastungen des Getriebes aufgeführt.

F Le réducteur de type **902C** est fourni sans lubrification et avec un bouchon de remplissage, de niveau et d'évacuation de l'huile. L'utilisateur peut y verser de l'huile minérale en conservant les bouchons existants. S'il y versera de l'huile synthétique, il devra substituer les bouchons existants avec d'autres bouchons de type fermé. Voir tableau 1 concernant les huiles et les quantités conseillées. Voir tableau 2 concernant les charges radiales et axiales applicables au réducteur

E El reductor tamaño **902C** se suministra sin lubricante, provisto de tapones de respiración, nivel y descarga de aceite. El usuario puede utilizar aceite mineral, manteniendo los tapones existentes. Si prefiere utilizar aceite sintético deberá sustituir los tapones existentes por tapones ciegos. La prerreducción se suministra con tapones ciegos, lubricado de por vida con aceite sintético. Ver tabla 1, para cantidades y aceites recomendados. En la tabla 2, se encuentran las cargas radiales y axiales admitidas por el reductor.

5.90 LT	3.80 LT	3.80 LT	3.40 LT	6.70 LT	4.40 LT	Ask

AGIP Blasia 460

For all details on lubrication and plugs check our website **tab. 1**
Per maggiori dettagli su lubrificazione e tappi olio vedi il nostro sito web

RADIAL AND AXIAL LOADS

Output shaft
Albero di uscita

$F_{eq} = FR \cdot \frac{88.5}{X + 38.5}$

n_2	FA	FR	n_2	FA	FR	n_2	FA	FR
300	2070	10350	140	2760	13800	70	3450	17250
250	2300	11500	120	2990	14950	40	3680	18400
200	2530	12650	85	3220	16100	15	4600	23000

On request reinforced bearings to increase loads.
A richiesta cuscinetti rinforzati per aumentare i carichi.

Input shaft
Albero in entrata

n_1	FA	FR
1400	700	3500
900	840	4200
500	900	4500

tab. 2

P902C**S8**... With feet
Con piedini

Gearbox weight **98.5 kg**
peso riduttore With feet **107.0 kg**

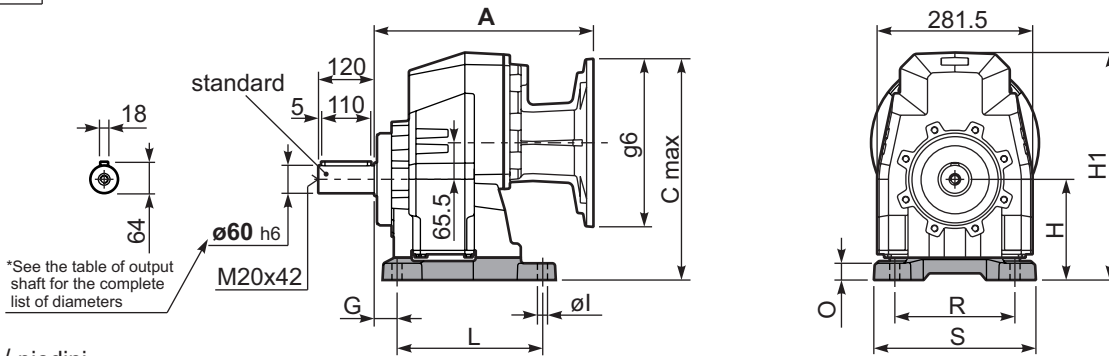

Feet / piedini

Feet Code	Market reference	G	H	R	L	S	H1	O	øl	B5 max. Flange	kit code
B6	612/3	25	195	250	180	300	422	25	18	-	KC90.9.022
S8	87	40	180	215	260	290	407	30	18	-	KC90.9.024
S9	97	40	225	250	310	340	452	45	22	-	KC90.9.026
H7	027/273	40	225	250	245	300	452	55	22	-	KC90.9.023
HS	-	40	175	215	260	290	402	25	18	-	KC90.9.025

P902C-**F**... Output flanges
flange di uscita

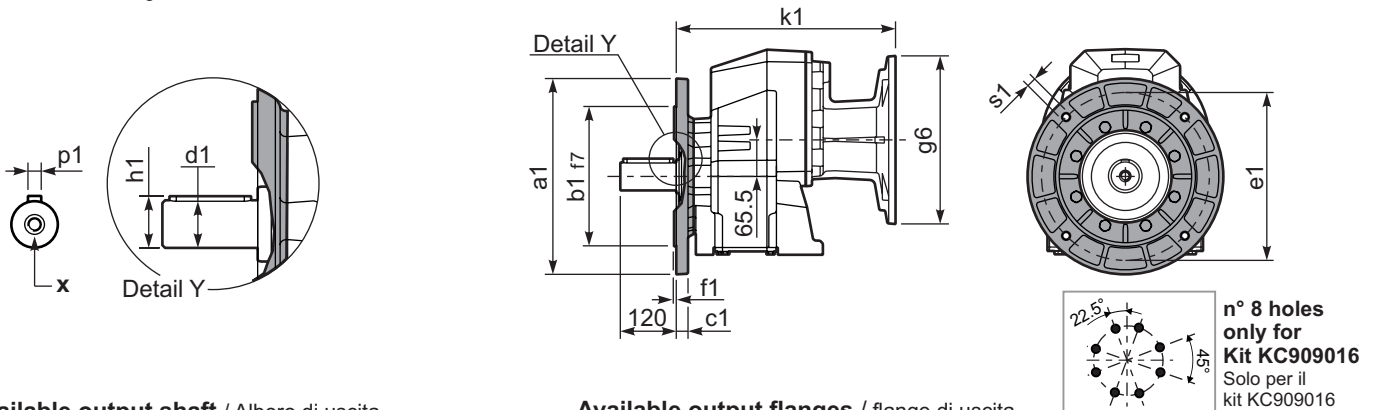

*Available output shaft / Albero di uscita

	Shaft - d1	p1	h1	x
Standard	ø 60x120	18	64	M20x42
On request A richiesta	ø 50x100	14	53.5	M16x36
	-	-	-	-

Available output flanges / flange di uscita

a1 ø	b1	c1	e1	f1	s1	kit code
300	230	21	265	4	14	KC90.9.014
350	250	21	300	5	18	KC90.9.015
450	350	22	400	5	18	KC90.9.016

With flange and feet only on request. Ask for compatibility

P902C-**N**... Basic gearbox
Riduttore base

R902C-**N**... Input Shaft
Albero in entrata

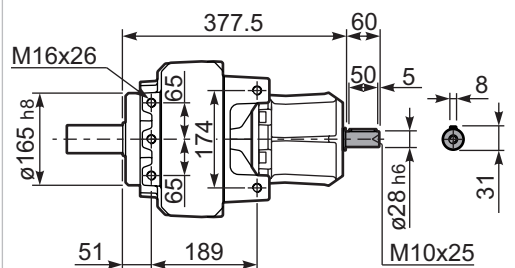
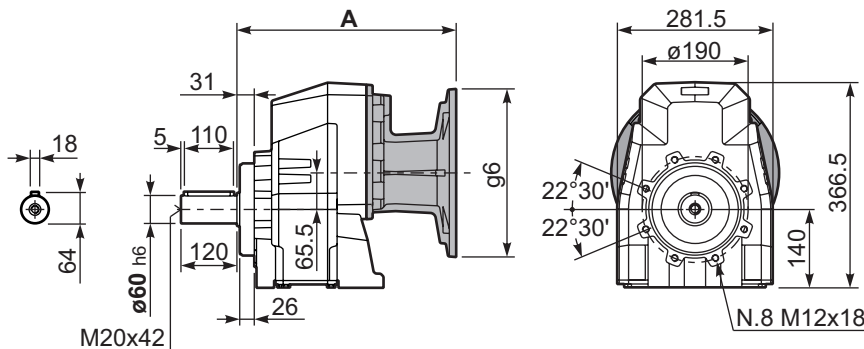

B5 Motor Flanges	A	C _{max}	g6	k1	kit code
100/112 B5	387	415.5	250	387	-
132 B5	391	440.5	300	391	-
160/180 B5	402	465.5	350	402	-