



QUICK SELECTION / Selezione veloce

input speed (n_1) = 1400 min⁻¹

Output Speed n_2 [min ⁻¹]	Ratio i	Motor power P_{1M} [kW]	Output torque M_{2M} [Nm]	Service factor $f.s.$	Nominal power P_{1R} [kW]	Nominal torque M_{2R} [Nm]	B5 motor flanges				B14 motor flanges				Output Shaft 	Ratios code
							-F	-G	-H	-I	-	-	-	-		
							100 112	132	160	180	-	-	-	-		
317	4.42	22	611	1.1	24.2	700	B							3015	01	
264	5.30	22	733	1.0	20.2	700	B							3013	02	
219	6.38	18.5	742	1.1	19.1	800	B							3011	03	
168	8.33	15	784	1.0	14.7	800	B							2015	04	
140	9.99	15	940	1.0	13.8	900	B							2013	05	
124	11.26	15	1060	1.0	14.9	1100	B							1615	06	
116	12.03	15	1132	1.1	15.2	1200	B							2011	07	
104	13.50	15	1271	1.1	15.8	1400	B							1613	08	
96	14.65	15	1378	1.1	15.6	1500	B							1315	09	
86	16.26	15	1531	1.0	14.1	1500	B							1611	10	
80	17.56	11	1214	1.2	13.0	1500	B							1313	11	
65	21.50	11	1486	1.1	11.4	1600	B							1113	12	
54	25.88	9	1526	1.0	9.4	1600	B							1111	13	
45.0	31.09	7.5	1475	1.0	7.2	1460	B							813	14	
37.4	37.43	5.5	1312	1.2	6.5	1600	B							811	15	

The dynamic efficiency is **0.96** for all ratios

Motor Flanges Available
Flange Motore Disponibili

B) Supplied with Reduction Bushing
Fornito con Bussola di Riduzione

B) Available on Request without reduction bushing
Disponibile a Richiesta senza Bussola di Riduzione

C) Motor Flange Holes Position
Posizione Fori Flangia Motore

EN Unit **852C** is supplied without lubricant and equipped with a breather, level and drain plugs. User can add mineral oil keeping existing plugs. Should the user wish to fill it with synthetic oil, it is recommended to replace the existing plugs with a closed plug.
See table 1 for lubrication and recommended quantity.
In table 2 please see possible radial loads and axial loads on the gearbox.

I Il riduttore tipo **852C** è fornito privo di lubrificazione con tappi di sfiato, livello e scarico olio. L'utente può immettere olio minerale mantenendo i tappi esistenti. Se immetterà olio sintetico, dovrà sostituire i tappi esistenti con altri tipo chiuso.
Tab.1 per oli e quantità consigliati.
Tab.2 carichi radiali e assiali applicabili al riduttore.

D Das Getriebe der Baugröße **852C** wird ohne Schmiermittel geliefert. Es ist jedoch mit Einfüllschraube, Überdruckventil und Ablassschraube ausgerüstet. Das benötigte mineralische Öl kann über die Einfüllschraube eingefüllt werden. Sollte synthetisches Öl bevorzugt werden, so ist sind das eingebaute Überdruckventil durch eine geschlossenen Schraube zu ersetzen.
In Tabelle 1 ist die Schmiermenge und das empfohlene Schmiermittel angegeben
In Tabelle 2 sind die zulässigen Radial - und Axialbelastungen des Getriebes aufgeführt.

F Le réducteur de type **852C** est fourni sans lubrification et avec un bouchon de remplissage, de niveau et d'évacuation de l'huile. L'utilisateur peut y verser de l'huile minérale en conservant les bouchons existants. S'il y versera de l'huile synthétique, il devra substituer les bouchons existants avec d'autres bouchons de type fermé.
Voir tableau 1 concernant les huiles et les quantités conseillées.
Voir tableau 2 concernant les charges radiales et axiales applicables au réducteur

E El reductor tamaño **852C** se suministra sin lubricante, provisto de tapones de respiración, nivel y descarga de aceite. El usuario puede utilizar aceite mineral, manteniendo los tapones existentes. Si prefiere utilizar aceite sintético deberá sustituir los tapones existentes por tapones ciegos. La prerreducción se suministra con tapones ciegos, lubricado de por vida con aceite sintético.
Ver tabla 1, para cantidades y aceites recomendados.
En la tabla 2, se encuentran las cargas radiales y axiales admitidas por el reductor.

B3	B6	B7	B8	V5	V6	V8
5.40 LT	3.60 LT	3.60 LT	2.80 LT	5.90 LT	4.20 LT	Ask

AGIP Blasias 460

For all details on lubrication and plugs check our website
Per maggiori dettagli su lubrificazione e tappi olio vedi il nostro sito web **tab. 1**

RADIAL AND AXIAL LOADS

Output shaft
Albero di uscita

$F_{eq} = FR \cdot \frac{88.5}{X+38.5}$

F_R (N) ↓
 F_A (N) ←

F_{eq} (N) ↓

n_2	FA	FR	n_2	FA	FR	n_2	FA	FR
300	1800	9000	140	2400	12000	70	3000	15000
250	2000	10000	120	2600	13000	40	3200	16000
200	2200	11000	85	2800	14000	15	4000	20000

On request reinforced bearings to increase loads.
A richiesta cuscinetti rinforzati per aumentare i carichi.

Input shaft
Albero in entrata

F_R (N) ↓
 F_A (N) ←

n_1	FA	FR
1400	700	3500
900	840	4200
500	900	4500

tab. 2

P852C-S8... With foot
Con piedino

Gearbox weight With flange **86.0 kg**
peso riduttore With feet **76.5 kg**

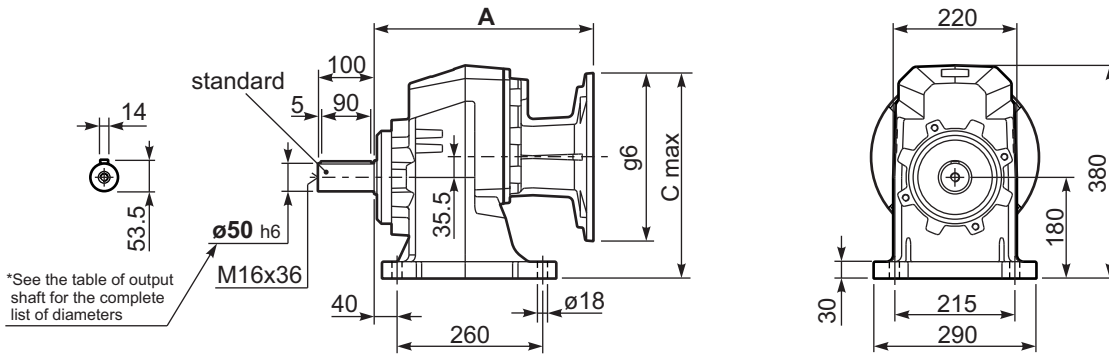

P852C-F... Output flanges
flange di uscita

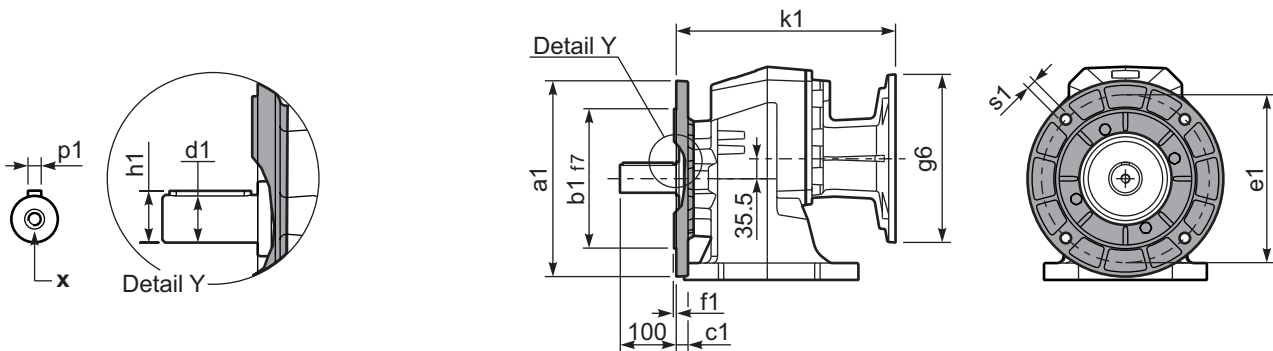

*Available output shaft / Albero di uscita

	Shaft - d1	p1	h1	x
Standard	∅ 50x100	14	53.5	M16x36
On request A richiesta	∅ 60x120	18	64	M20x42
	-	-	-	-

Available output flanges / flange di uscita

a1 ∅	b1	c1	e1	f1	s1	kit code
300	230	21	265	4	14	KC90.9.014
350	250	21	300	5	18	KC90.9.015
-	-	-	-	-	-	-

All flanges are compatible with the foot

P852C-S8... Basic gearbox
Riduttore base

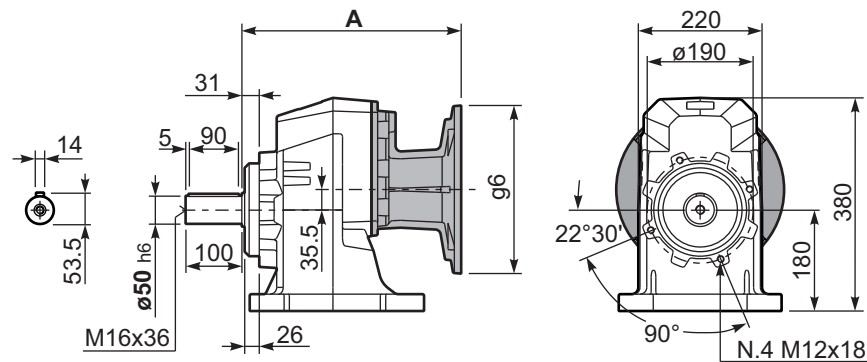

B5 Motor Flanges	A	C _{max}	g6	k1	kit code
100/112 B5	387	340.5	250	387	-
132 B5	391	365.5	300	391	-
160/180 B5	402	390.5	350	402	-

R852C-S8... Input Shaft
Albero in entrata

