



QUICK SELECTION / Selezione veloce

input speed (n_1) = 1400 min⁻¹

Output Speed n_2 [min ⁻¹]	Ratio i	Motor power P_{1M} [kW]	Output torque M_{2M} [Nm]	Service factor $f.s.$	Nominal power P_{1R} [kW]	Nominal torque M_{2R} [Nm]	Available B5 motor flanges					Available B14 motor flanges				Output Shaft			
							C	D	E	F	G	R	T	U	V			Ratios code	
							71	80	90	100 112	132*	80	90	100 112	132				
388	3.61	7.5	171	1.1	7.6	180	B										3018		01
331	4.23	7.5	200	1.1	8.0	220	B										3016		02
279	5.01	7.5	238	1.1	7.9	260	B										3014		03
231	6.07	7.5	288	1.0	7.6	300	B										3012		04
206	6.81	7.5	323	1.1	7.9	350	B										2018		05
176	7.96	7.5	378	1.0	7.1	370	B										2016		07
148	9.45	5.5	331	1.2	6.5	400	B										2014	standard	08
122	11.43	5.5	401	1.0	5.5	415	B										2012	ø35	09
100	14.00	4	359	1.2	4.7	435	B										1316		10
84	16.62	4	426	1.2	4.7	515	B										1314	ø28	11
70	20.10	4	515	1.0	4.0	520	B										1312	ø30	12
57	24.61	3	475	1.1	3.2	520	B										1112	ø38	20
47.6	29.41	2.2	418	1.1	2.3	450	B										814	ø40	14
39.3	35.58	1.85	431	1.2	2.2	520	B										812	On request	15
34.6	40.50	1.1	290	1.1	1.2	320	B										614		16
31.7	44.23	1.5	433	0.9	1.4	400	B										810		17
28.6	49.00	1.1	351	1.1	1.2	400	B										612		18
23.0	60.90	1.1	436	0.9	1.0	400	B										610		19

The dynamic efficiency is **0.96** for all ratios *Nel montaggio P la flangia può superare l'ingombro massimo dei piedi. Eventualmente utilizzare la flangia B14 * In the P mounting the B5 motor flange can exceed the foot maximum dimensions. Possibly use the flange B14

- Motor Flanges Available** Flange Motore Disponibili
- B) Supplied with Reduction Bushing** Fornito con Bussola di Riduzione
- B) Available on Request without reduction bushing** Disponibile a Richiesta senza Bussola di Riduzione
- C) Motor Flange Holes Position** Posizione Fori Flangia Motore

EN Unit **602A** is supplied with synthetic oil for lifetime lubrication, no maintenance is necessary. See table 1 for lubrication and recommended quantity. In table 2 please see possible radial loads and axial loads on the gearbox.

I Il riduttore **602A** viene fornito completo di olio sintetico per la lubrificazione permanente e non necessita di alcuna manutenzione. Vedi tab.1 per oli e quantità consigliati. In tab.2 sono presenti i carichi radiali e assiali applicabili al riduttore.

D Das Getriebe **602A** ist mit synthetischem Öl gefüllt und ist lebensdauergeschmiert. In Tabelle 1 ist die Schmiermenge und das empfohlene Schmiermittel angegeben. In Tabelle 2 sind die zulässigen Radial- und Axialbelastungen des Getriebes aufgeführt.

F Le réducteur **602A** est fourni complet avec de l'huile synthétique pour la lubrification permanente et ne nécessite aucun entretien. Voir tableau 1 concernant les huiles et les quantités conseillées. Les charges radiales et axiales applicables au réducteur sont précisées dans le tableau 2.

E El reductor tamaño **602A** se suministra, lubricado de por vida con aceite sintético y no requieren mantenimiento alguna. Ver tabla 1, para cantidades y aceites recomendados. En la tabla 2, se encuentran las cargas radiales y axiales admitidas por el reductor.

Standard supplied	For these mounting position specify in the order or add oil					
	Per queste posizioni specificare in fase d'ordine o aggiungere olio					
0.55 LT	0.85 LT	1.10 LT	1.20 LT	1.20 LT	1.25 LT	Ask
AGIP Telium VSF 320			SHELL Omala S4 WE 320			

For all details on lubrication and plugs check our website **tab. 1**
Per maggiori dettagli su lubrificazione e tappi olio vedi il nostro sito web

RADIAL AND AXIAL LOADS

Output shaft
Albero di uscita

$F_{eq} = F_R \cdot \frac{60.5}{X+25.5}$

$F_{eq} (N)$

n_2	FA	FR	n_2	FA	FR	n_2	FA	FR
300	560	2800	140	740	3700	70	890	4200
250	600	3000	120	760	3800	40	1160	5800
200	640	3200	85	840	4000	15	1300	6500

Input shaft
Albero di entrata

n_1	FA	FR
1400	450	2250
900	500	2500
500	600	3000

tab. 2

P602A-B1... With feet
Con piedini

Gearbox weight
peso riduttore With flange **14.1 kg**
With feet **14.5 kg**

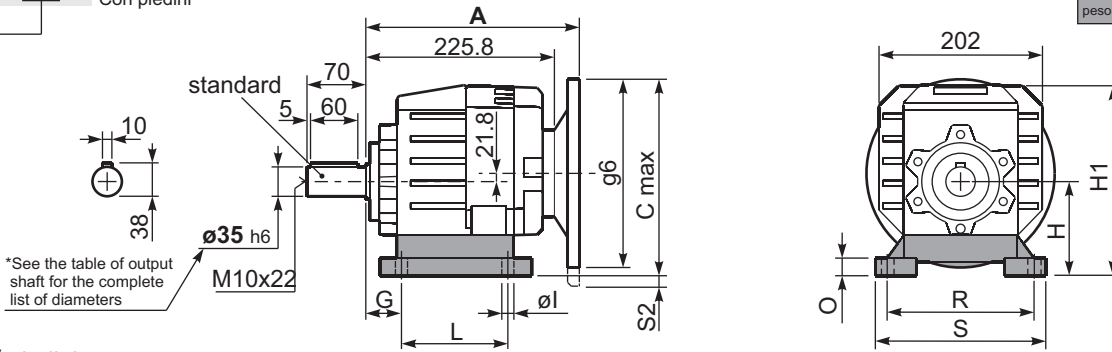

Feet / piedini

Feet Code	Market reference	G	H	R	L	S	H1	O	øl	S2 only with motor flange	B5 max. Flange	kit code
B4	412/3	20	130	180	149.5	216	233	18	14	-	-	KC60.9.024
S4	47-57	30	115	135	165	170	218	24	13.5	13 132B5	-	KC50.9.022
M3	62/3	35	120	170-185	110	230	223	20	14	8 132B5	-	KC60.9.023
S7	77	35	140	170	205	204	243	8	14	-	-	KC60.9.029LM
H4	024-243	35	155	170	150	225	258	30	14	-	-	KC60.9.025
L6	06	19	125	160	106	205	228	8	14	3 132B5	-	KC50.9.026LM
E3	2302/3	19.5	125	170	240	205	228	8	14	-	100/112B5	KC60.9.026LM
P6	162	40	162	160	205	200	265	8	14	-	-	KC60.9.027LM
B5	352/3	23.5	115	170	130	205	218	8	14	13 132B5	-	KC60.9.021LM

Other feet are available, see our web site
Sono disponibili altri piedini, consulta il nostro sito web

A see on page bottom

Most popular types
Tipi più diffusi

P602A-F... Output flanges
flange di uscita

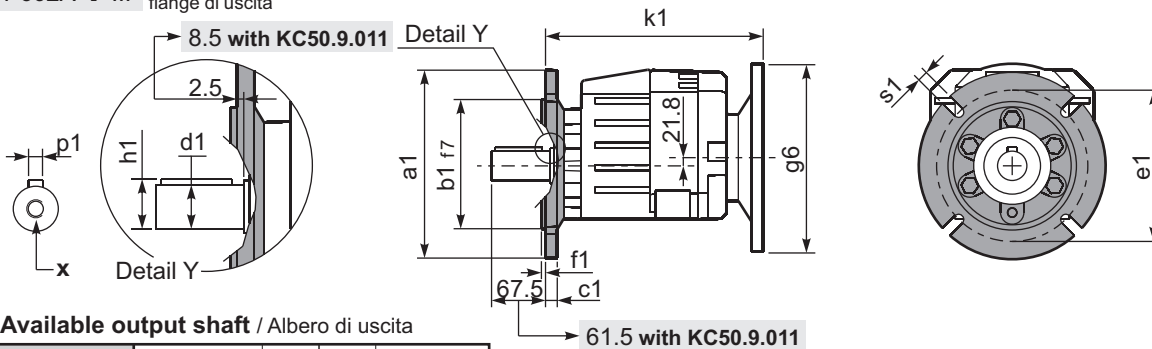

*Available output shaft / Alberi di uscita

	Shaft - d1	p1	h1	x
Standard	ø 35x70	10	38	M10x22
On request A richiesta	ø 28x60	8	31	M8x20
	ø 30x60	8	33	M10x22
	ø 38x70	10	41	M10x25
	ø 40x80	12	43	M12x28

Available output flanges / flange di uscita

a1 ø	b1	c1	e1	f1	s1	kit code
160	110	14	130	3.5	11	KC50.9.011
200	130	13	165	3.5	11	KC50.9.012
250	180	15.5	215	4	14	KC50.9.013

With flange and feet only on request.
Ask for compatibility

P602A-N... Basic gearbox
Riduttore base

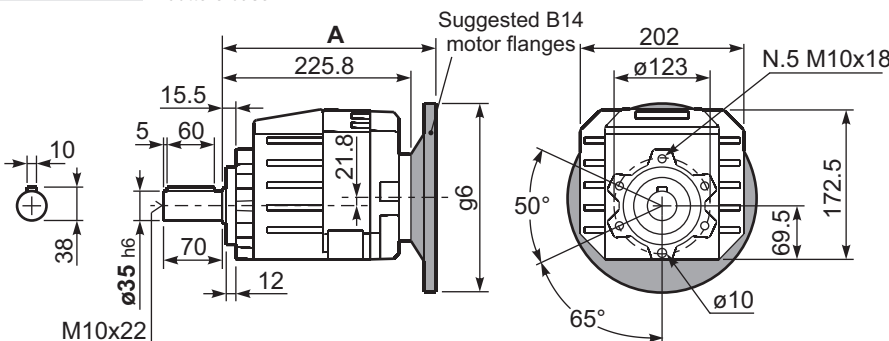

R602A-N... Input Shaft
Albero in entrata

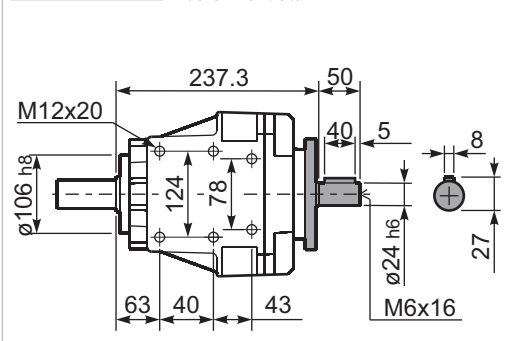

B5 Motor Flanges	A	C _{max}	g6	k1	kit code	k1 with KC50.9.011	B14 Motor Flanges	A	C _{max}	g6	k1	kit code	k1 with KC50.9.011
71 B5	244.3	263.8	160	246.8	KC023.4.041	252.8	80 B14	246.3	243.8	120	248.8	KC085.4.046	254.8
80/90 B5	246.3	283.8	200	248.8	KC023.4.042	254.8	90 B14	246.3	253.8	140	248.8	KC085.4.045	254.8
100/112 B5	255.3	308.8	250	257.8	KC023.4.043	263.8	100/112 B14	255.3	263.8	160	257.8	KC085.4.047	263.8
132 B5	273.3	333.8	300	275.8	KC50.4.043	281.8	132 B14	273.3	283.8	200	275.8	KC50.4.041	281.8