



#### QUICK SELECTION / Selezione veloce

input speed (n<sub>1</sub>) = 1400 min<sup>-1</sup>

Output Speed n <sub>2</sub> [min <sup>-1</sup> ]	Ratio i	Motor power P <sub>1M</sub> [kW]	Output torque M <sub>2M</sub> [Nm]	Service factor f.s.	Nominal power P <sub>1R</sub> [kW]	Nominal torque M <sub>2R</sub> [Nm]	Available B5 motor flanges					Available B14 motor flanges				Output Shaft		
							-B	-C	-D	-E	-F	-Q	-R	-T	-U			Ratios code
							63	71	80*	90*	100*	71	80	90	100	112	100	
398	3.52	3	68	1.2	3.5	80	B					C	C			2821		01
321	4.37	3	84	1.1	3.1	90	B					C	C			2818		02
252	5.56	3	107	0.9	2.7	100	B					C	C			2813		03
220	6.36	2.2	90	1.1	2.3	95	B					C	C			1921		04
191	7.33	2.2	104	1.2	2.5	120	B					C	C			2812		05
177	7.89	2.2	112	1.1	2.3	120	B					C	C			1918		06
139	10.06	2.2	143	1.0	2.3	150	B					C	C			1913		08
120	11.66	1.5	114	1.5	2.3	174	B					C	C			1713	standard	09
106	13.26	1.5	130	1.2	1.8	160	B					C	C			1912	ø25	10
102	13.68	1.5	134	1.1	1.6	144	B					C	C			1513		25
91	15.37	1.5	151	1.1	1.6	160	B					C	C			1712	ø16	11
86	16.20	1.5	159	0.9	1.3	138	B					C	C			1910	ø19	12
78	18.04	1.5	177	0.9	1.4	160	B					C	C			1512	ø20	23
75	18.78	1.1	134	1.0	1.1	138	B					C	C			1710	ø24	24
65	21.54	1.1	154	1.0	1.1	160	B					C	C			1312	On request	14
63	22.29	1.1	160	1.0	1.1	167	B					C	C			1013		15
53	26.31	0.75	129	1.1	0.80	138	B					C	C			1310		16
47.6	29.40	0.75	144	1.1	0.83	160	B					C	C			1012		17
39	35.91	0.55	130	1.1	0.59	138	B					C	C			1010		18
36.5	38.37	0.55	139	1.2	0.64	160	B					C	C			912		19
29.9	46.87	0.55	170	0.8	0.45	138	B					C	C			910		20
27.6	50.67	0.37	123	1.1	0.40	132	B					C	C			712		21
22.6	61.89	0.37	150	0.9	0.34	138	B					C	C			710		22

The dynamic efficiency is **0.96** for all ratios

\*Nel montaggio P la flangia può superare l'ingombro massimo dei piedi. Eventualmente utilizzare la flangia B14  
\* In the P mounting the B5 motor flange can exceed the foot maximum dimensions. Possibly use the flange B14

**A** Motor Flanges Available  
Flange Motore Disponibili

**B** Supplied with Reduction Bushing  
Fornito con Bussola di Riduzione

**C** Available on Request without reduction bushing  
Disponibile a Richiesta senza Bussola di Riduzione

**D** Motor Flange Holes Position  
Posizione Fori Flangia Motore

**EN** Unit **402A** is supplied with synthetic oil for lifetime lubrication, no maintenance is necessary. See table 1 for lubrication and recommended quantity. In table 2 please see possible radial loads and axial loads on the gearbox.

**I** Il riduttore **402A** viene fornito completo di olio sintetico per la lubrificazione permanente e non necessita di alcuna manutenzione. Vedi tab.1 per oli e quantità consigliati. In tab.2 sono presenti i carichi radiali e assiali applicabili al riduttore.

**D** Das Getriebe **402A** ist mit synthetischem Öl gefüllt und ist lebensdauergeschmiert. In Tabelle 1 ist die Schmiermenge und das empfohlene Schmiermittel angegeben. In Tabelle 2 sind die zulässigen Radial - und Axialbelastungen des Getriebes aufgeführt.

**F** Le réducteur **402A** est fourni complet avec de l'huile synthétique pour la lubrification permanente et ne nécessite aucun entretien. Voir tableau 1 concernant les huiles et les quantités conseillées. Les charges radiales et axiales applicables au réducteur sont précisées dans le tableau 2.

**E** El reductor tamaño **402A** se suministra, lubricado de por vida con aceite sintético y no requieren mantenimiento alguna. Ver tabla 1, para cantidades y aceites recomendados. En la tabla 2, se encuentran las cargas radiales y axiales admitidas por el reductor.

Standard supplied	For these mounting position specify in the order or add oil					
	Per queste posizioni specificare in fase d'ordine o aggiungere olio					
B3	B6	B7	B8	V5	V6	V8
0.25 LT	0.30 LT	0.40 LT	0.40 LT	0.40 LT	0.50 LT	Ask
AGIP Telium VSF 320			SHELL Omala S4 WE 320			

For all details on lubrication and plugs check our website **tab. 1**  
Per maggiori dettagli su lubrificazione e tappi olio vedi il nostro sito web

### RADIAL AND AXIAL LOADS

**Output shaft**  
Albero di uscita

$F_{eq} = F_R \cdot \frac{46}{X+21}$

n <sub>2</sub>	FA	FR	n <sub>2</sub>	FA	FR	n <sub>2</sub>	FA	FR
300	310	1550	140	406	2030	70	540	2700
250	330	1650	120	448	2240	40	600	3000
200	360	1800	85	480	2400	15	600	3000

**Input shaft**  
Albero in entrata

n <sub>1</sub>	FA	FR
1400	240	1200
900	280	1400
500	340	1700

**tab. 2**

P402A**B1** ... With feet  
Con piedini

Gearbox weight **5.7 kg**  
peso riduttore With feet **5.9 Kg**

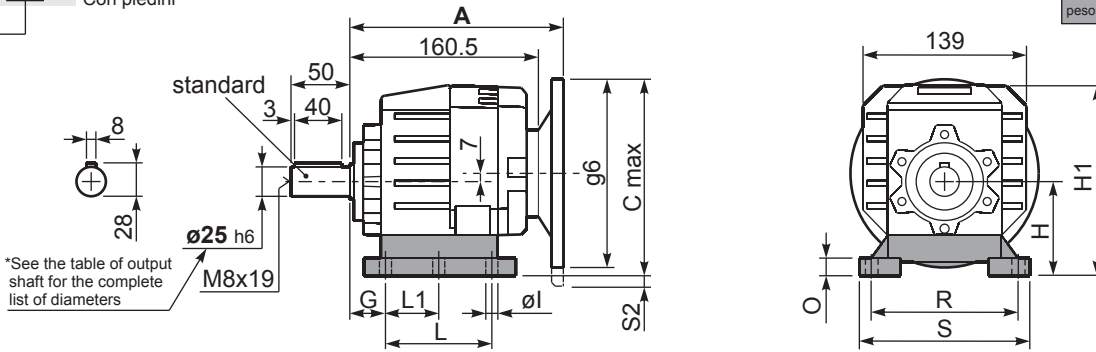

**Feet / piedini**

Feet Code	Market reference	G	H	R	L	L1	S	H1	O	øl	S2 only with motor flange	B5 max. Flange	kit code
B1	112	18	85	110	87	50	130	167	15	-	8/33 80/90B5 100/112B5	-	KC35.9.021
B2	212/3	18	100	130	107.5	60	155	182	17	11	18 100/112B5	-	KC40.9.025
S1	17	18	75	110	90÷110	50	145	155	15	9	18/43 80/90B5 100/112B5	-	KC40.9.022
S2	27	25	90	110	130	-	145	172	20	9	3/28 80/90B5 100/112B5	-	KC40.9.024
H2	022-223	25	100	110	115	-	145	182	20	9	18 100/112B5	-	KC40.9.026
M1	42/3	25	80	110÷120	85	-	145	162	15	9	13/38 80/90B5 100/112B5	-	KC40.9.023
L4	04	13	80	105	76	-	132	162	5	10	13/38 80/90B5 100/112B5	-	KC35.9.023LM
L5	05	16	100	125	90	-	150	182	6	12	18 100/112B5	-	KC40.9.027LM

Other feet are available, see our web site  
Sono disponibili altri piedini, consulta il nostro sito web

**A see on page bottom**

Most popular types  
Tipi più diffusi

P402A-**F** ... Output flanges  
flange di uscita

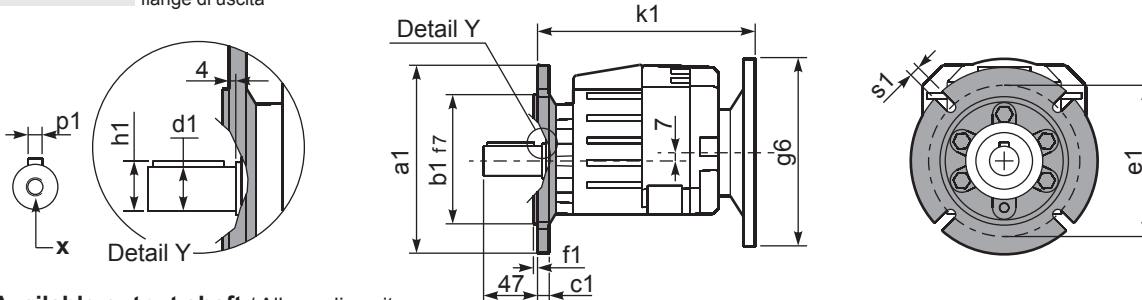

**\*Available output shaft / Albero di uscita**

	Shaft - d1	p1	h1	x
Standard	ø 25x50	8	28	M8x19
On request A richiesta	ø 16x40	5	18	M6x16
	ø 19x40	6	21.5	M6x16
	ø 20x40	6	22.5	M8x19
	ø 24x50	8	27	M8x19

**Available output flanges / flange di uscita**

a1 ø	b1	c1	e1	f1	s1	kit code
120	80	10	100	3	7	KC40.9.010
140	95	10	115	3	9	KC40.9.011
160	110	10	130	3	9	KC40.9.012
200	130	11	165	3.5	11	KC40.9.013
250	180	11.5	215	3.5	14	KC40.9.014

With flange and feet only on request. Ask for compatibility

P402A-**N** ... Basic gearbox  
Riduttore base

R402A-**N** ... Input Shaft  
Albero in entrata

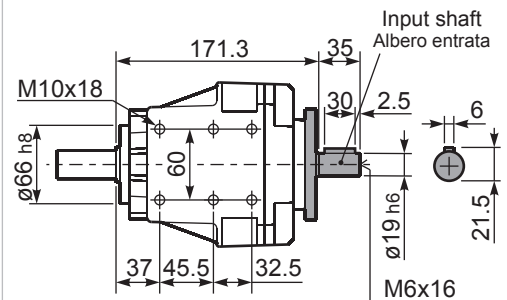
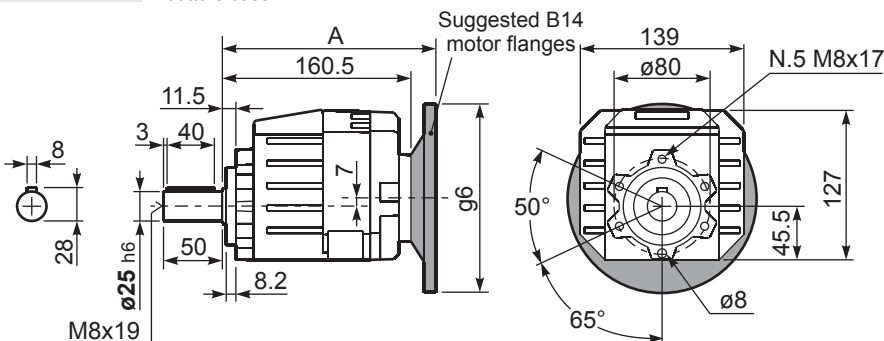

B5 Motor Flanges	A	C <sub>max</sub>	g6	k1	kit code
63 B5	181	177	140	185	K063.4.041
71 B5	179	187	160	183	K063.4.042
80/90 B5	181	207	200	185	K063.4.043
100/112 B5	195.8	232	250	199.8	KC40.4.043

B14 Motor Flanges	A	C <sub>max</sub>	g6	k1	kit code
71 B14	179	159.5	105	183	K063.4.047
80 B14	181	167	120	185	K063.4.046
90 B14	181	177	140	185	K063.4.041
100/112 B14	195.8	187	160	199.8	KC40.4.041