

QUICK SELECTION / Selezione veloce

input speed (n_1) = 1400 min⁻¹

Output Speed n_2 [min ⁻¹]	Ratio i	Motor power P_{1M} [kW]	Output torque M_{2M} [Nm]	Service factor f.s.	Nominal power P_{1R} [kW]	Nominal torque M_{2R} [Nm]	Available B5 motor flanges				Available B14 motor flanges			Dynamic efficiency RD	Tooth Module [mm]	Ratios code 	
							B	C	D	E	Q	R	T				
							63	71	80	90	71	80	90				
200	7	1.8	71	1.8	3.2	125		B	B			B-C	B-C		83	3.1	01
140	10	1.8	99	1.4	2.4	134		B	B			B-C	B-C		81	3.1	02
93	15	1.5	121	1.1	1.7	138		B	B			B-C	B-C		79	3.1	03
74	19	1.1	111	1.2	1.4	138		B	B			B-C	B-C		78	2.6	04
58	24	1.1	135	1.0	1.2	142		B	B			B-C	B-C		75	2.0	05
47	30	1.1	167	0.9	0.96	146		B	B			B-C	B-C		74	3.2	06
39	36	0.75	125	1.2	0.88	147		B	B	B		B-C	B-C		68	2.7	07
31	45	0.55	111	1.2	0.67	135	B	B				B-C	C		66	2.1	08
23	60	0.55	140	0.9	0.51	130	B	B				B-C	C		62	1.6	12
21	67	0.55	151	0.8	0.45	124	B	B				B-C	C		60	1.5	09
17.5	80	0.37	115	1.0	0.38	119	B	B				B-C	C		57	1.3	10
14.9	94	0.37	123	1.0	0.36	119	B	B				B-C	C		52	1.1	11

Motor Flanges Available
Flange Motore Disponibili

B) Supplied with Reduction Bushing
Fornito con Bussola di Riduzione

B) Available on Request without reduction bushing
Disponibile a Richiesta senza Bussola di Riduzione

C) Motor Flange Holes Position
Posizione Fori Flangia Motore

EN Unit **063** is supplied with synthetic oil, providing "long life" lubrication. For mounting position V5-V6 please contact us. See table 1 for lubrication and recommended quantity. In table 2 please see possible radial loads and axial loads on the gearbox.

I Il riduttore tipo **063** viene fornito lubrificato a vita con olio sintetico. Per posizioni V5-V6 contattare il ns. servizio tecnico. Vedi tab.1 per oli e quantità consigliati. In tab.2 sono presenti i carichi radiali e assiali applicabili al riduttore.

D Für die Lebensdauerschmierung ist das Getriebe der Größe **063** mit synthetischem Öl befüllt. Bei Einbaulage V5 oder V6 bitten wir um Rücksprache. In Tabelle 1 ist die Schmiermenge und das empfohlene Schmiermittel angegeben. In Tabelle 2 sind die zulässigen Radial - und Axialbelastungen des Getriebes aufgeführt.

F Le réducteur de type **063** est fourni lubrifié à vie avec de l'huile synthétique. Concernant les positions V5.V6, contactez notre service d'assistance technique. Voir tableau 1 concernant les huiles et les quantités conseillées. Les charges radiales et axiales applicables au réducteur sont précisées dans le tableau 2.

E El reductor tamaño **063** se suministra, lubricado de por vida con aceite sintético. Para las posiciones V5 y V6 contactar con nuestro servicio técnico. Ver tabla 1, para cantidades y aceites recomendados. En la tabla 2, se encuentran las cargas radiales y axiales admitidas por el reductor.

LUBRICATION 063 Oil Quantity 0.40 Lt.

AGIP Telium VSF 320

SHELL Omala S4 WE 320

For all details on lubrication and plugs check our website **tab. 1**
Per maggiori dettagli su lubrificazione e tappi olio vedi il nostro sito web

RADIAL AND AXIAL LOADS

Output shaft

Albero di uscita

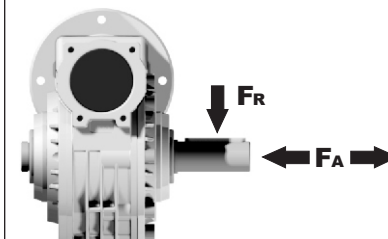

n_2 [min ⁻¹]	FA [N]	FR [N]
200	360	1800
150	400	2000
100	460	2300
75	500	2500
50	600	3000
25	700	3800
15	800	4000

Input shaft

albero in entrata

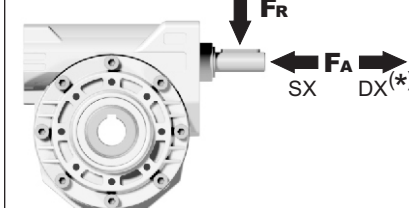

n_1 [min ⁻¹]	FA [N]	FR [N]
1400	90	450

***Strong axial loads in the DX direction are not allowed.**
Non sono consentiti forti carichi assiali con direzione DX

tab. 2

P063FB... Basic wormbox
Riduttore base

Gearbox weight
peso riduttore **6.00 kg**

M. flanges	Kit code	øF	A
63B5	K063.4.041	140	99.5
71B5	K063.4.042	160	97.5
80/90B5	K063.4.043	200	99.5
71B14	K063.4.047	105	97.5
80B14	K063.4.046	120	99.5
90B14	K063.4.041	140	99.5

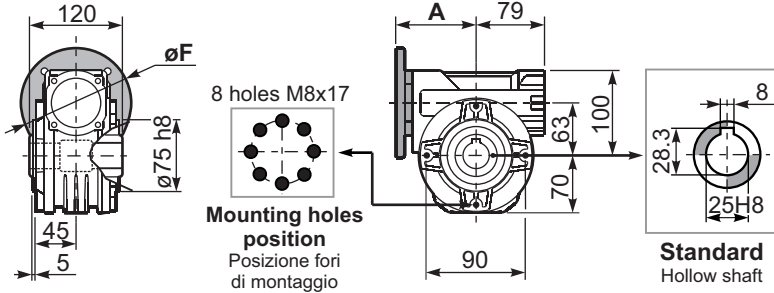

P063PA... Feet
Piedini

P063PB... Feet
Piedini

P063PV... Feet
Piedini

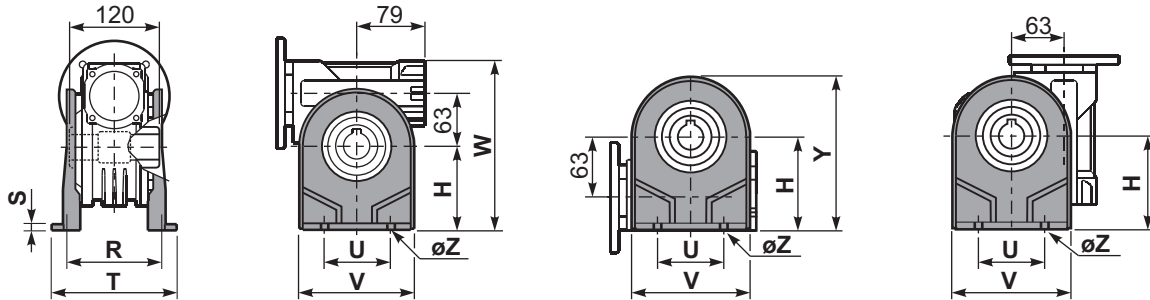

	H	R	S	T	U	V	Y	W	øZ	kit code
type B	100	111	4	144	95	133	170	200	ø10.5	K063.9.022
type S	-	-	-	-	-	-	-	-	-	-

P063FC... Output flange
Flangia uscita

P063BR... Reaction arm
Braccio di reazione

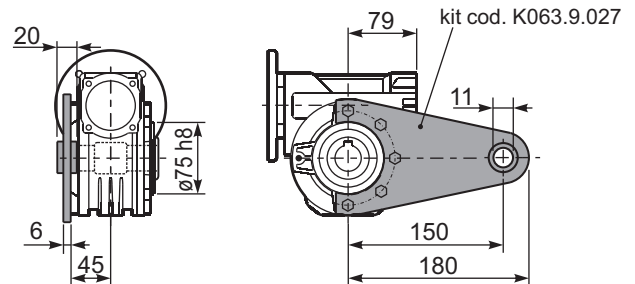
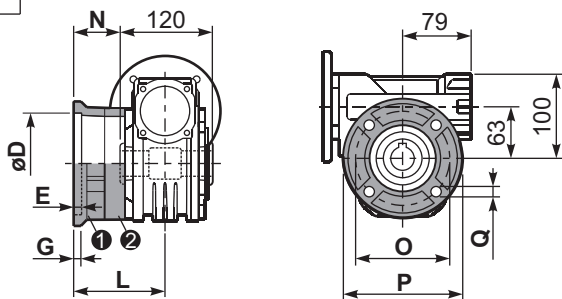

type B	øD	E	G	L	N	O	P	Q	kit code
FC	115 ^{+0.20} / _{+0.15}	7	13	86	26	150	175	11	① K063.9.010 ② -
FL	115 ^{+0.20} / _{+0.15}	7	13	116	56	150	175	11	① K063.9.010 ② K063.0.200

type S	øD	E	G	L	N	O	P	Q	kit code
F1	130 ^{+0.20} / _{+0.15}	7	13	102	42	165	200	13	① KS070.9.013 ② -
F2	115 ^{+0.20} / _{+0.15}	7	13	116	56	150	175	11	① KS063.9.013 ② -
F3	110 ^{+0.035} / ₀	5	11	82	22	130	160	10	① KS063.9.011 ② -

P063.....S... Single Shaft
Albero lento semplice

P063.....D... Double Shaft
Albero lento bisp.

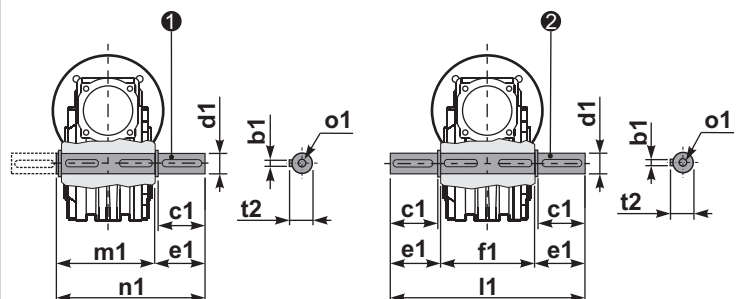

① kit cod. K063.5.028 type B

② kit cod. K063.5.029 type B

R063FB... Input shaft
Albero in entrata

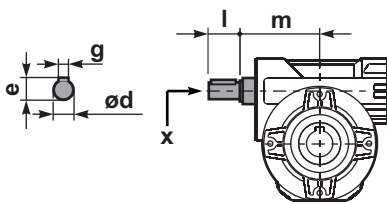

	ød	e	g	l	m	x	kit code
type B	18 h6	20.5	6	45	93	M6x16	① K063.5.006 PAM80 ② K063.5.007 PAM90
type S	19 h6	21.5	6	40	93	M8x20	① KS063.5.008 PAM80 ② KS063.5.009 PAM90

	b1	c1	d1	e1	f1	l1	m1	n1	t2	o1
type B	8	60	25 ^{-0.005} / _{-0.020}	63.2	120	246.4	126.8	190	28	M8x20
type S	-	-	-	-	-	-	-	-	-	-