



### QUICK SELECTION / Selezione veloce

input speed ( $n_1$ ) = 1400 min<sup>-1</sup>

Output Speed $n_2$ [min <sup>-1</sup> ]	Ratio $i$	Motor power $P_{1M}$ [kW]	Output torque $M_{2M}$ [Nm]	Service factor f.s.	Nominal power $P_{1R}$ [kW]	Nominal torque $M_{2R}$ [Nm]	Available B5 motor flanges				Available B14 motor flanges			Dynamic efficiency  RD	Tooth Module  Mn [mm]	Ratios code 	
							C	D	E	F	R	T	U				
							71	80	90	100 112	80	90	100 112				
200	7	4	172	1.1	4.4	190		B	B			B	B		90	3.75	01
140	10	4	240	1.0	3.8	230		B	B			B	B		88	3.75	02
93	15	3	261	1.0	2.9	250		B	B			B	B		85	3.75	03
70	20	2.2	249	1.0	2.2	250		B	B			B	B		83	3.00	04
56	25	1.5	205	1.2	1.83	250	B	B				B			80	2.41	05
45	31	1.5	244	1.1	1.66	270	B	B				B			77	3.75	06
35	40	1.5	295	0.9	1.30	255	B	B				B			72	3.10	07
28	50	0.75	174	1.3	0.95	220	B								68	2.41	08
23	60	0.75	202	1.0	0.75	200	B								65	2.10	09
17.5	80	0.55	177	1.0	0.56	180	B								59	1.53	10
14.0	100	0.55*	206	0.7	0.40	150	B								55	1.23	11

Motor Flanges Available  
Flange Motore Disponibili

B) Supplied with Reduction Bushing  
Fornito con Bussola di Riduzione

B) Available on Request without reduction bushing  
Disponibile a Richiesta senza Bussola di Riduzione

C) Motor Flange Holes Position  
Posizione Fori Flangia Motore

**EN** Unit Q75 is supplied with synthetic oil, providing "long life" lubrication. For mounting position V5-V6 please contact us. See table 1 for lubrication and recommended quantity. In table 2 please see possible radial loads and axial loads on the gearbox. For complete documentation please visit our web site.

**I** Il riduttore tipo Q75 viene fornito lubrificato a vita con olio sintetico. Per posizioni V5-V6 contattare il ns. servizio tecnico. Vedi tab.1 per oli e quantità consigliati. In tab.2 sono presenti i carichi radiali e assiali applicabili al riduttore. Per la documentazione completa consulta il nostro sito.

**D** Für die Lebensdauerschmierung ist das Getriebe der Größe Q75 mit synthetischem Öl befüllt. Bei Einbaulage V5 oder V6 bitten wir um Rücksprache. In Tabelle 1 ist die Schmiermenge und das empfohlene Schmiermittel angegeben. In Tabelle 2 sind die zulässigen Radial- und Axialbelastungen des Getriebes aufgeführt. Die komplette Dokumentation, Wartungs- und Inbetriebnahmeanleitungen finden Sie unter.

**E** El reductor tamaño Q75 se suministra, lubricado de por vida con aceite sintético. Para las posiciones V5 y V6 contactar con nuestro servicio técnico. Ver tabla 1, para cantidades y aceites recomendados. En la tabla 2, se encuentran las cargas radiales y axiales admitidas por el reductor. Para documentación completa, consultar nuestra Web.

### LUBRICATION Q75 Oil Quantity 0.40 Lt.

AGIP Telium VSF 320

SHELL Omala S4 WE 320

For all details on lubrication and plugs check our website **tab. 1**  
Per maggiori dettagli su lubrificazione e tappi olio vedi il nostro sito web

### RADIAL AND AXIAL LOADS

Output shaft  
Albero di uscita

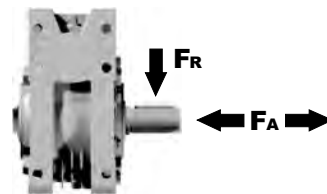

$n_2$ [min <sup>-1</sup> ]	FA [N]	FR [N]
200	460	2300
150	520	2600
100	560	2800
75	620	3100
50	720	3600
25	880	4400
15	1000	5000

Input shaft  
albero in entrata

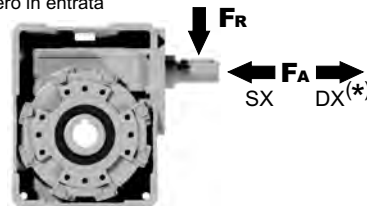

$n_1$ [min <sup>-1</sup> ]	FA [N]	FR [N]
1400	125	630

\*Strong axial loads in the DX direction are not allowed.  
Non sono consentiti forti carichi assiali con direzione DX

tab. 2

SELECT THIS TYPE AND THIS SPECIFIC SIZE ON THE WEB PAGES TO GET COMPLETE TECHNICAL DATA.  
Selezionare tipo e gandezza specifica nel sito web per la documentazione completa.

**PQ75FB...** Basic wormbox  
Riduttore base

Gearbox weight  
peso riduttore **8.70 kg**

M. flanges	Kit code	øF	A
<b>71B5</b>	K023.4.041	160	113.5
<b>80/90B5</b>	K023.4.042	200	115.5
<b>100/112B5</b>	K023.4.043	250	121.5
<b>80B14</b>	K085.4.046	120	113.5
<b>90B14</b>	K085.4.045	140	113.5
<b>100/112B14</b>	K023.4.041	160	113.5

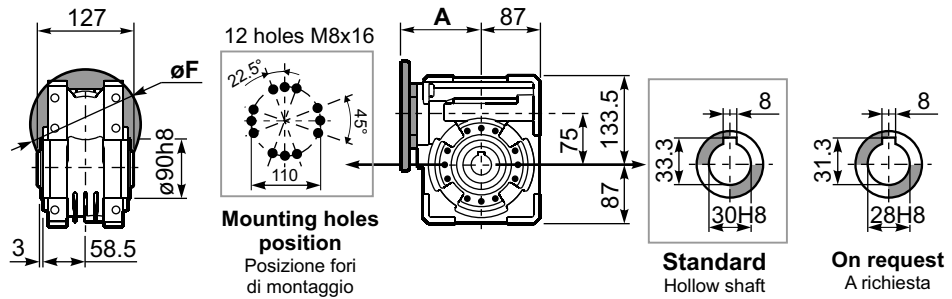

**PQ75FC...** Square flange  
Flangia quadrata

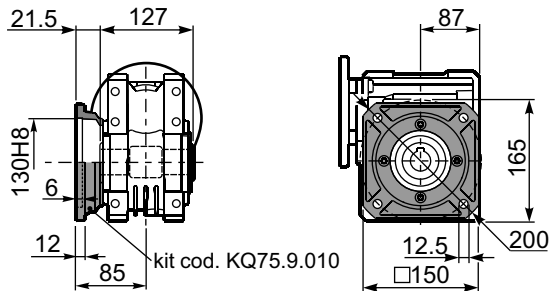

**PQ75FL...** Square flange  
Flangia quadrata

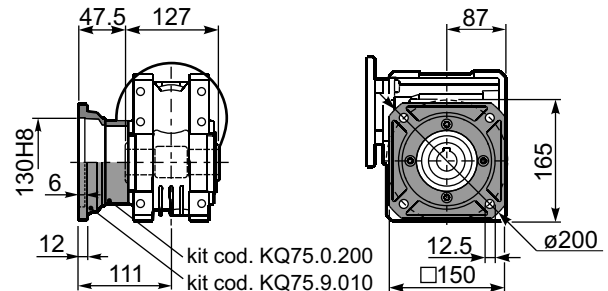

**PQ75FB...** Feet  
Piedini

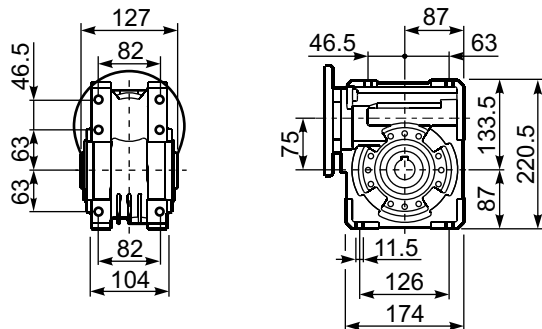

**PQ75BR...** Reaction arm  
Braccio di reazione

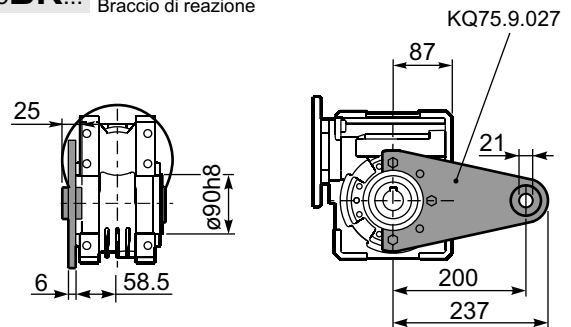

**RQ75FB...** Input shaft  
Albero in entrata

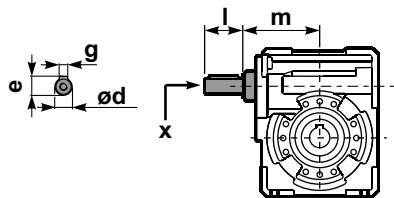

**PQ75.....S...** Single Shaft  
Albero lento semplice

**PQ75.....D...** Double Shaft  
Albero lento bisp.

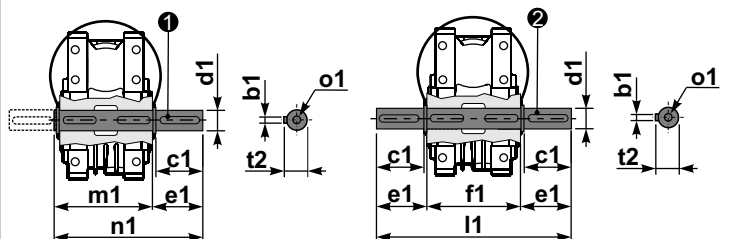

① kit cod. KQ75.5.028 Standard  
kit cod. KQ75.5.026 On request

② kit cod. KQ75.5.029 Standard  
kit cod. KQ75.5.027 On request

	ød	e	g	l	m	x	kit code
type B	25 h6	27.8	8	50	109.5	M8x20	KQ75.5.006 PAM80 K085.5.007 PAM90 K085.5.008 PAM100

	b1	c1	d1	e1	f1	l1	m1	n1	t2	o1
Standard	8	60	30 <sup>-0.005</sup> <sub>-0.020</sub>	65	127	255	134	199	33	M8x20
On request	8	60	28 <sup>-0.005</sup> <sub>-0.020</sub>	65	127	255	134	199	31	M8x20