

# PULEGGE DENTATE HTD CON FORO INIZIALE

## IDENTIFICAZIONE DI UNA PULEGGIA

**34 - 8M - 50** ———— 34 N° denti  
8M passo in mm  
50 larghezza cinghia

**TL 30 - 14M - 55** ———— TL Taper Lock  
30 N° denti  
14M passo in mm  
55 larghezza cinghia

## VALORI DELLA EQUILIBRATURA DELLA PULEGGIA

Le pulegge **HTD**® di nostra produzione non vengono equilibrate.

L'equilibratura si esegue al costo solo su richiesta.

Siamo in grado di equilibrare pulegge fino ad un diametro massimo di 560 mm con rilascio del certificato

## CARATTERISTICHE DELLE GOLE

DIAMETRI PULEGGE	LARGHEZZA FASCIA	MAX SQUILIBRIO IN GRAMMI
da 199 - 301	60	6
da 302 - 599	60	10
da 199 - 301	da 60 - 90	10
da 302 - 599		15
da 600 - 999		20
oltre 1000		30
da 199 - 301	da 100 - 199	20
da 302 - 599		30
da 600 - 999		40
oltre 1000		60

## TOLLERANZE DI COSTRUZIONE

De Puleggia Tolleranza in mm

da Ø 0 a Ø 30	- 0	+ 0.05
da Ø 31 a Ø 50	- 0	+ 0.08
da Ø 51 a Ø 100	- 0	+ 0.10
da Ø 101 a Ø 179	- 0	+ 0.13
da Ø 180 a Ø 300	- 0	+ 0.15
da Ø 301 a Ø 500	- 0	+ 0.18
da Ø oltre Ø 51	- 0	+ 0.20

## ECCENTRICITA'

Il foro e il diametro esterno devono essere concentrici in base alle tolleranze sotto indicate

Ø esterno mm	Eccentricità totale (mm) Indicazione totale del comparatore
fino a 199	0.10
oltre 200	0.0005 per mm di Ø Questo valore non può superare la tolleranza sul Ø esterno

# ESECUZIONI PULEGGE DENTATE HTD®

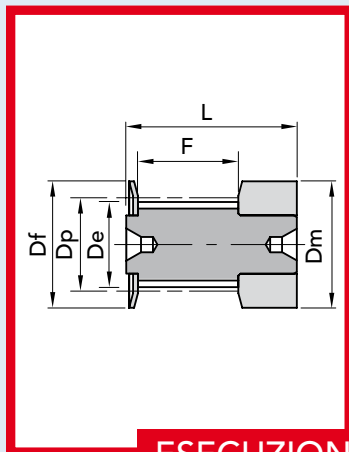

**ESECUZIONE 0F**

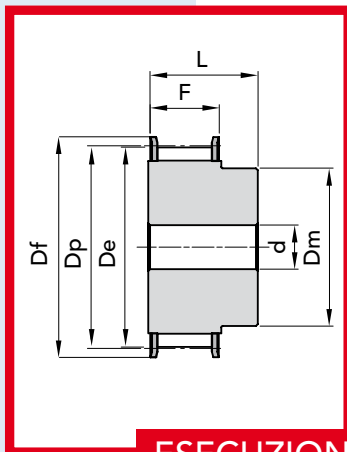

**ESECUZIONE 1F**

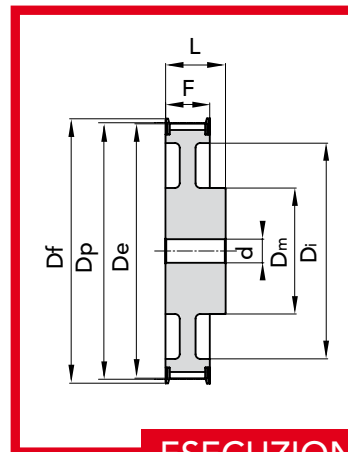

**ESECUZIONE 2F**

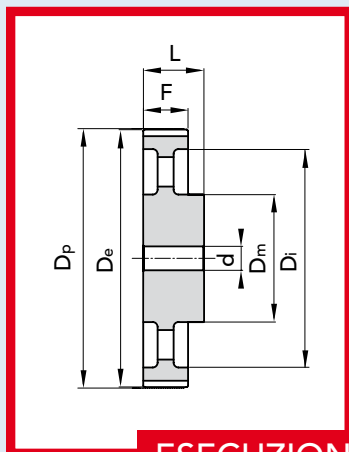

**ESECUZIONE 3**

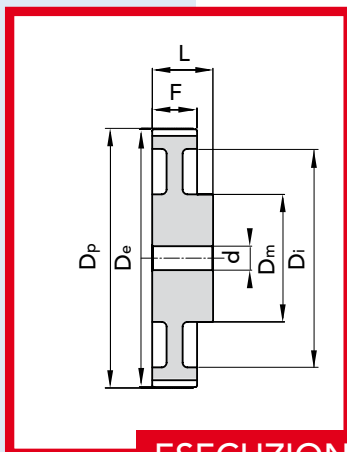

**ESECUZIONE 4**

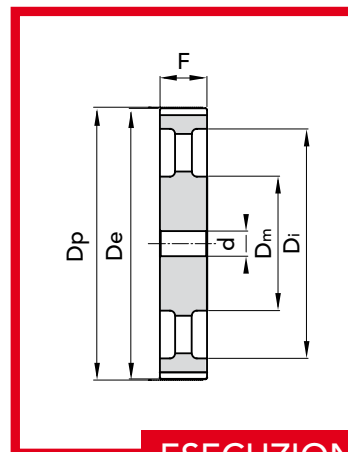

**ESECUZIONE 5**

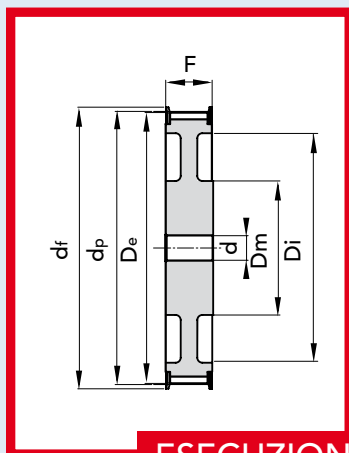

**ESECUZIONE 6F**

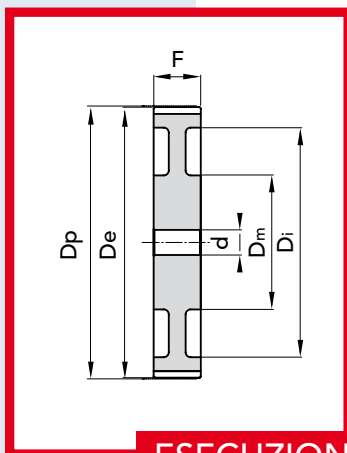

**ESECUZIONE 7**

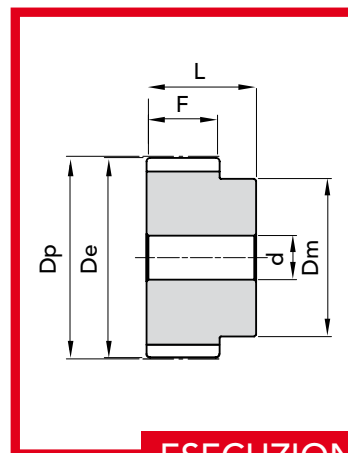

**ESECUZIONE 8**

# PULEGGE DENTATE HTD® CON FORO INIZIALE

PULEGGE DENTATE HTD® CON FORO INIZIALE 3M 09

TIPO **3M 09**

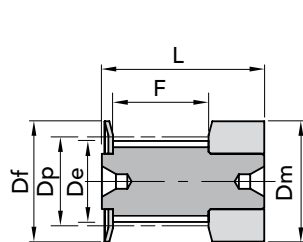

ESEC. 0F

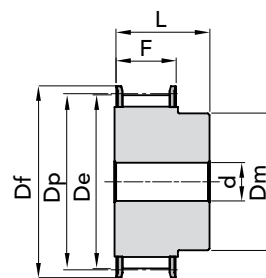

ESEC. 1F

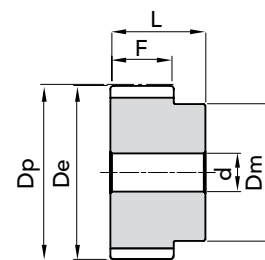

ESEC. 8

TIPO	CODICE	N. DENTI	ESEC.	Dp	De	Df FLANGIA	Dm MOZZO	F	L	d Ø FORO	N. FLANGIA	Peso kg.
10- 3M- 09F	40109010	10	0F	9,55	8,79	13	13	10,2	18	-	501	0,01
12- 3M- 09F	40109012	12	0F	11,46	10,70	15	15	10,2	18	-	502	0,01
14- 3M- 09F	40109014	14	0F	13,37	12,61	16	16	10,2	18	-	503	0,01
15- 3M- 09F	40109015	15	0F	14,32	13,56	18	17,5	10,2	18	-	516	0,01
16- 3M- 09F	40109016	16	1F	15,28	14,52	17,5	10	12,8	13	4	504	0,01
18- 3M- 09F	40109018	18	1F	17,19	16,43	20	11	12,8	13	6	505	0,01
20- 3M- 09F	40109020	20	1F	19,10	18,34	23	13	12,8	13	6	517	0,01
21- 3M- 09F	40109021	21	1F	20,05	19,29	25	13	12,8	13	6	518	0,01
22- 3M- 09F	40109022	22	1F	21,01	20,25	25	13	12,8	13	6	518	0,01
24- 3M- 09F	40109024	24	1F	22,92	22,16	25	13	12,8	13	6	518	0,02
26- 3M- 09F	40109026	26	1F	24,83	24,07	28	16	12,8	13	6	508	0,02
28- 3M- 09F	40109028	28	1F	26,74	25,98	32	18	12,8	13	6	509	0,02
30- 3M- 09F	40109030	30	1F	28,65	27,89	32	20	12,8	13	6	509	0,30
32- 3M- 09F	40109032	32	1F	30,56	29,80	36	22	12,8	13	6	510	0,30
36- 3M- 09F	40109036	36	1F	34,38	33,62	39	26	13,4	13	6	519	0,05
40- 3M- 09F	40109040	40	1F	38,20	37,44	42	28	13,4	13	6	513	0,06
44- 3M- 09	40109044	44	1F	42,02	41,26	48	33	13,4	13	6	520	0,07
48- 3M- 09	40109048	48	8	45,84	45,08	-	33	13,4	13	8	-	0,11
60- 3M- 09	40109060	60	8	57,30	56,54	-	33	13,4	13	8	-	0,11
72- 3M- 09	40109072	72	8	68,75	67,99	-	33	13,4	13	8	-	0,15



MATERIALE **ALLUMINIO**

Disegni CAD disponibili sul sito  
[www.chiaravalli.com](http://www.chiaravalli.com)

# PULEGGE DENTATE HTD® CON FORO INIZIALE

TIPO **3M 15**

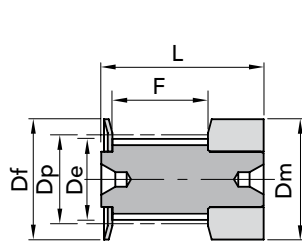

ESEC. 0F

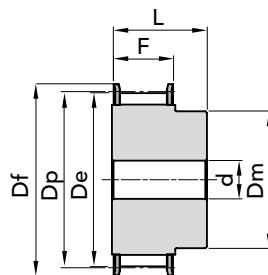

ESEC. 1F

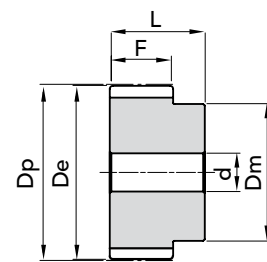

ESEC. 8

TIPO	CODICE	N. DENTI	ESEC.	Dp	De	Df FLANGIA	Dm MOZZO	F	L	d Ø FORO	N. FLANGIA	Peso kg.
10- 3M- 15F	40115010	10	0F	9,55	8,79	13	13	17	26	-	501	0,01
12- 3M- 15F	40115012	12	0F	11,46	10,70	15	15	17	26	-	502	0,01
14- 3M- 15F	40115014	14	0F	13,37	12,61	16	16	17	26	-	503	0,01
15- 3M- 15F	40115015	15	0F	14,32	13,56	17,5	17,5	17	26	-	516	0,01
16- 3M- 15F	40115016	16	1F	15,28	14,52	18	10	19,5	26	4	504	0,01
18- 3M- 15F	40115018	18	1F	17,19	16,43	20	11	19,5	26	6	505	0,01
20- 3M- 15F	40115020	20	1F	19,10	18,34	23	13	19,5	26	6	517	0,01
21- 3M- 15F	40115021	21	1F	20,05	19,29	25	13	19,5	26	6	518	0,02
22- 3M- 15F	40115022	22	1F	21,01	20,25	25	13	19,5	26	6	518	0,02
24- 3M- 15F	40115024	24	1F	22,92	22,16	25	13	19,5	26	6	518	0,02
26- 3M- 15F	40115026	26	1F	24,83	24,07	28	16	19,5	26	6	508	0,03
28- 3M- 15F	40115028	28	1F	26,74	25,98	32	18	19,5	26	6	509	0,03
30- 3M- 15F	40115030	30	1F	28,65	27,89	32	20	19,5	26	6	509	0,04
32- 3M- 15F	40115032	32	1F	30,56	29,80	36	22	19,5	26	6	510	0,04
36- 3M- 15F	40115036	36	1F	34,38	33,62	39	26	20	30	6	519	0,06
40- 3M- 15F	40115040	40	1F	38,20	37,44	42	28	20	30	6	513	0,08
44-3M- 15	40115044	44	1F	42,02	41,26	48	33	20	30	6	520	0,10
48- 3M- 15	40115048	48	8	45,84	45,08	-	33	20	30	8	-	0,10
60- 3M- 15	40115060	60	8	57,30	56,54	-	33	20	30	8	-	0,15
72- 3M- 15	40115072	72	8	68,75	67,99	-	33	20	30	8	-	0,21

MATERIALE **ALLUMINIO**



# PULEGGE DENTATE HTD® CON FORO INIZIALE

PULEGGE DENTATE HTD® CON FORO INIZIALE "FOSFATATE" 5M 09

FOSFATATE

TIPO **5M 09**

Le pulegge in alluminio non sono fosfatate

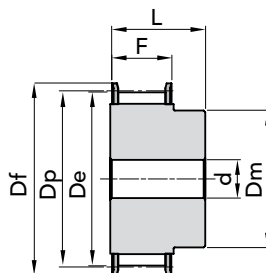

ESEC. 1F

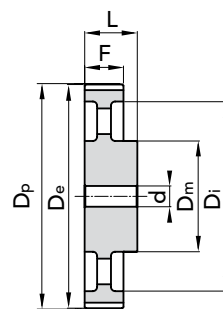

ESEC. 3

TIPO	CODICE	N. DENTI	ESEC.	Dp	De	Df FLANGIA	Dm MOZZO	Di	F	L	d Ø FORO	N. FLANGIA	Peso kg.
12- 5M- 09F	40209012	12	1F	19,10	17,96	23	12	-	14,5	20	4	14	0,03
14- 5M- 09F	40209014	14	1F	22,28	21,14	25	13	-	14,5	20	6	2	0,04
15- 5M- 09F	40209015	15	1F	23,37	22,73	28	16	-	14,5	20	6	4	0,05
16- 5M- 09F	40209016	16	1F	25,46	24,32	28	16,5	-	14,5	20	6	4	0,06
18- 5M- 09F	40209018	18	1F	28,65	27,51	32	20	-	14,5	20	6	6	0,07
20- 5M- 09F	40209020	20	1F	31,83	30,69	36	23	-	14,5	23	6	8	0,10
21- 5M- 09F	40209021	21	1F	33,52	32,28	38	24	-	14,5	23	6	9	0,12
22- 5M- 09F	40209022	22	1F	35,01	33,87	39	25,5	-	14,5	23	6	15	0,13
24- 5M- 09F	40209024	24	1F	38,20	37,06	42	27	-	14,5	23	6	13	0,15
26- 5M- 09F	40209026	26	1F	41,38	40,24	44	30	-	14,5	23	6	12	0,18
28- 5M- 09F	40209028	28	1F	44,56	43,42	48	30,5	-	14,5	23	6	11	0,21
30- 5M- 09F	40209030	30	1F	47,75	46,60	51	35	-	14,5	23	6	16	0,25
32- 5M- 09F	40209032	32	1F	50,93	49,79	54	38	-	14,5	26	8	18	0,28
36- 5M- 09F	40209036	36	1F	57,30	56,16	60	38	-	14,5	26	8	21	0,33
40- 5M- 09F	40209040	40	1F	63,66	62,52	71	38	-	14,5	26	8	25	0,42
44- 5M- 09	40209044	44	3	70,03	68,89	-	38	54	14,5	26	8	-	0,17
48- 5M- 09	40209048	48	3	76,39	75,25	-	45	61	14,5	26	8	-	0,18
60- 5M- 09	40209060	60	3	95,49	94,35	-	45	80	14,5	26	8	-	0,23
72- 5M- 09	40209072	72	3	114,59	113,45	-	45	100	14,5	26	8	-	0,42

MATERIALE ACCIAIO

MATERIALE ALLUMINIO



# PULEGGE DENTATE HTD® CON FORO INIZIALE

FOSFATATE

TIPO **5M 15**

Le pulegge in alluminio non sono fosfatate

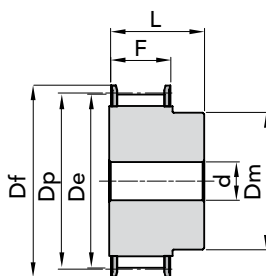

ESEC. 1F

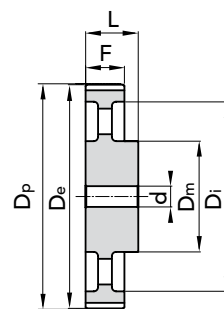

ESEC. 3

TIPO	CODICE	N. DENTI	ESEC.	Dp	De	Df FLANGIA	Dm MOZZO	Di	F	L	d Ø FORO	N. FLANGIA	Peso kg.
12- 5M- 15F	40215012	12	1F	19,10	17,96	23	12	-	20,5	26	-	14	0,03
14- 5M- 15F	40215014	14	1F	22,28	21,14	25	13	-	20,5	26	6	2	0,04
15- 5M- 15F	40215015	15	1F	23,37	22,73	28	16	-	20,5	26	6	4	0,05
16- 5M- 15F	40215016	16	1F	25,46	24,32	28	16,5	-	20,5	26	6	4	0,06
18- 5M- 15F	40215018	18	1F	28,65	27,51	32	20	-	20,5	26	6	6	0,09
20- 5M- 15F	40215020	20	1F	31,83	30,69	36	23	-	20,5	26	6	8	0,12
21- 5M- 15F	40215021	21	1F	33,52	32,28	38	24	-	20,5	26	6	9	0,14
22- 5M- 15F	40215022	22	1F	35,01	33,87	39	25,5	-	20,5	26	6	15	0,15
24- 5M- 15F	40215024	24	1F	38,20	37,06	42	27	-	20,5	28	6	13	0,19
26- 5M- 15F	40215026	26	1F	41,38	40,24	44	30	-	20,5	28	6	12	0,23
28- 5M- 15F	40215028	28	1F	44,56	43,42	48	30,5	-	20,5	28	6	11	0,26
30- 5M- 15F	40215030	30	1F	47,75	46,60	51	35	-	20,5	28	6	16	0,32
32- 5M- 15F	40215032	32	1F	50,93	49,79	54	38	-	20,5	28	8	18	0,35
36- 5M- 15F	40215036	36	1F	57,30	56,16	60	38	-	20,5	28	8	21	0,43
40- 5M- 15F	40215040	40	1F	63,66	62,52	71	38	-	20,5	28	8	25	0,52
44- 5M- 15	40215044	44	3	70,03	68,89	-	38	54	20,5	30	8	-	0,23
48- 5M- 15	40215048	48	3	76,39	75,25	-	45	61	20,5	30	8	-	0,29
60- 5M- 15	40215060	60	3	95,49	94,35	-	45	80	20,5	30	8	-	0,30
72- 5M- 15	40215072	72	3	114,59	113,45	-	45	100	20,5	30	8	-	0,59

MATERIALE ACCIAIO

MATERIALE ALLUMINIO



Le immagini non sono identificative del prodotto.

PULEGGE DENTATE HTD® CON FORO INIZIALE "FOSFATATE" 5M 15

# PULEGGE DENTATE HTD® CON FORO INIZIALE

FOSFATATE

TIPO **5M 25**

Le pulegge in alluminio non sono fosfatate

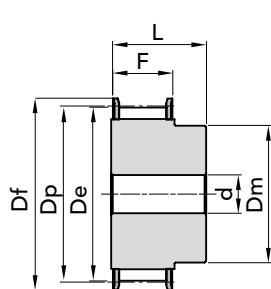

ESEC. 1F

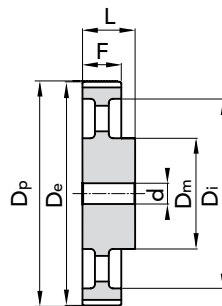

ESEC. 3

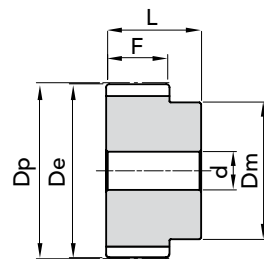

ESEC. 8

TIPO	CODICE	N. DENTI	ESEC.	Dp	De	Df FLANGIA	Dm MOZZO	Di	F	L	d Ø FORO	N. FLANGIA	Peso kg.
12- 5M- 25F	40225012	12	1F	19,10	17,96	23	12	-	30,5	36	-	14	0,05
14- 5M- 25F	40225014	14	1F	22,28	21,14	25	13	-	30,5	36	6	2	0,08
15- 5M- 25F	40225015	15	1F	23,37	22,73	28	16	-	30,5	36	6	4	0,09
16- 5M- 25F	40225016	16	1F	25,46	24,32	28	16,5	-	30,5	36	6	4	0,11
18- 5M- 25F	40225018	18	1F	28,65	27,51	32	20	-	30,5	36	6	6	0,13
20- 5M- 25F	40225020	20	1F	31,83	30,69	36	23	-	30,5	36	6	8	0,17
21- 5M- 25F	40225021	21	1F	33,52	32,28	38	24	-	30,5	38	6	9	0,20
22- 5M- 25F	40225022	22	1F	35,01	33,87	39	25,5	-	30,5	38	6	15	0,22

# PULEGGE DENTATE HTD® CON FORO INIZIALE

FOSFATATE

TIPO **8M 20**

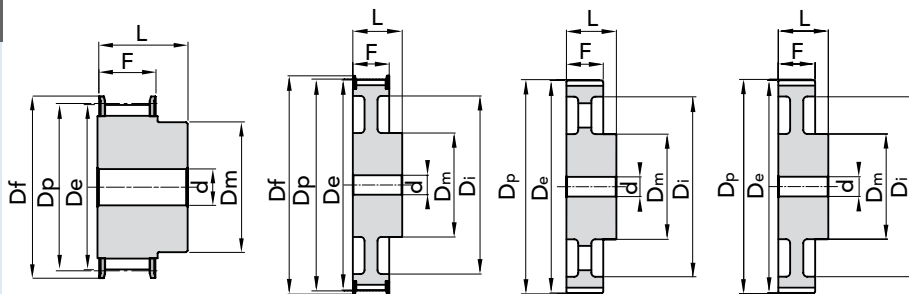

ESEC. 1F

ESEC. 2F

ESEC. 3

ESEC. 4

TIPO	CODICE	N. DENTI	ESEC.	Dp	De	Df FLANGIA	Dm MOZZO	Di	F	L	d Ø FORO	N. FLANGIA	Peso kg.
22- 8M- 20F	40420022	22	1F	56,02	54,65	60	43	-	28	38	12	53	0,54
24- 8M- 20F	40420024	24	1F	61,12	59,75	66	45	-	28	38	12	69	0,65
26- 8M- 20F	40420026	26	1F	66,21	64,85	70	48	-	28	38	12	61	0,80
28- 8M- 20F	40420028	28	1F	71,30	70,08	75	50	-	28	38	15	79	0,88
30- 8M- 20F	40420030	30	1F	76,39	75,13	82,5	55	-	28	38	15	64	1,00
32- 8M- 20F	40420032	32	1F	81,49	80,16	87	60	-	28	38	15	76	1,20
34- 8M- 20F	40420034	34	1F	86,58	85,22	91	66	-	28	38	15	66	1,40
36- 8M- 20F	40420036	36	1F	91,67	90,30	97	70	-	28	38	15	68	1,60
38- 8M- 20F	40420038	38	1F	96,77	95,39	102	75	-	28	38	15	70	1,70
40- 8M- 20F	40420040	40	1F	101,86	100,49	106	75	-	28	38	15	77	1,85
44- 8M- 20F	40420044	44	1F	112,05	110,67	120	75	-	28	38	15	75	2,10
48- 8M- 20F	40420048	48	1F	122,23	120,86	128	75	-	28	38	15	78	2,50
56- 8M- 20F	40420056	56	2F	142,60	141,23	150	80	116	28	38	15	85	2,82
64- 8M- 20F	40420064	64	2F	162,97	161,60	168	80	137	28	38	15	90	3,22
72- 8M- 20F	40420072	72	2F	183,35	181,97	192	80	158	28	38	15	97	3,74
80- 8M- 20	40420080	80	3	203,72	202,35	-	90	180	28	38	15	-	3,78
90- 8M- 20	40420090	90	3	229,18	227,81	-	90	204	28	38	15	-	4,57
112- 8M- 20	a richiesta	112	4	285,21	283,83	-	90	254	28	38	18	-	-
144- 8M- 20	40420144	144	4	366,69	365,32	-	90	336	28	38	20	-	5,2
168- 8M- 20	a richiesta	168	4	488,92	487,55	-	100	400	28	38	20	-	-
192- 8M- 21	a richiesta	192	4	488,92	487,55	-	100,0	460	28,0	38	20	-	-

MATERIALE **ACCIAIO**

MATERIALE **GHISA**



Le immagini non sono identificative del prodotto.

PULEGGE DENTATE HTD® CON FORO INIZIALE "FOSFATATE" 8M 20



# PULEGGE DENTATE HTD® CON FORO INIZIALE

PULEGGE DENTATE HTD® CON FORO INIZIALE "FOSFATE" 8M 30

FOSFATE

TIPO **8M 30**

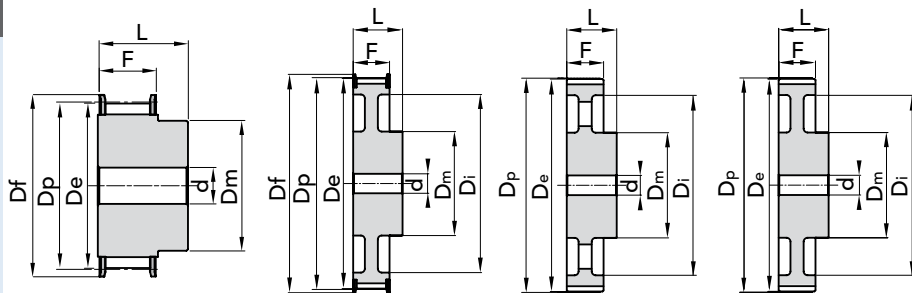

ESEC. 1F

ESEC. 2F

ESEC. 3

ESEC. 4

TIPO	CODICE	N. DENTI	ESEC.	Dp	De	Df FLANGIA	Dm MOZZO	Di	F	L	d Ø FORO	N. FLANGIA	Peso kg.
22- 8M- 30F	40430022	22	1F	56,02	54,65	60	43	-	38	48	12	53	0,75
24- 8M- 30F	40430024	24	1F	61,12	59,75	66	45	-	38	48	12	69	0,90
26- 8M- 30F	40430026	26	1F	66,21	64,85	70	48	-	38	48	12	61	1,10
28- 8M- 30F	40430028	28	1F	71,30	70,08	75	50	-	38	48	15	79	1,20
30- 8M- 30F	40430030	30	1F	76,39	75,13	82,5	55	-	38	48	15	73	1,32
32- 8M- 30F	40430032	32	1F	81,49	80,16	87	60	-	38	48	15	76	1,55
34- 8M- 30F	40430034	34	1F	86,58	85,22	91	66	-	38	48	15	66	1,80
36- 8M- 30F	40430036	36	1F	91,67	90,30	97	70	-	38	48	15	68	2,10
38- 8M- 30F	40430038	38	1F	96,77	95,39	102	75	-	38	48	15	70	2,30
40- 8M- 30F	40430040	40	1F	101,86	100,49	106	75	-	38	48	15	77	2,47
44- 8M- 30F	40430044	44	1F	112,05	110,67	120	75	-	38	48	15	75	2,95
48- 8M- 30F	40430048	48	1F	122,23	120,86	128	75	-	38	48	15	78	3,30
56- 8M- 30F	40430056	56	2F	142,60	141,23	150	90	116	38	48	15	85	4,02
64- 8M- 30F	40430064	64	2F	162,97	161,60	168	90	137	38	48	15	90	4,60
72- 8M- 30F	40430072	72	2F	183,35	181,97	192	95	158	38	48	15	97	5,41
80- 8M- 30	40430080	80	3	203,72	202,35	-	100	180	38	48	15	-	5,23
90- 8M- 30	40430090	90	3	229,18	227,81	-	100	204	38	48	15	-	6,42
112- 8M- 30	40430112	112	4	285,21	283,83	-	100	224	38	48	18	-	8,12
144- 8M- 30	40430144	144	4	366,69	365,32	-	100	336	38	48	20	-	10,36
168- 8M- 30	40430168	168	4	427,81	426,44	-	100	400	38	48	20	-	12,37
192- 8M- 30	40430192	192	4	488,92	487,55	-	100	460	38	48	20	-	14,31

MATERIALE ACCIAIO

MATERIALE GHISA



# PULEGGE DENTATE HTD® CON FORO INIZIALE

FOSFATATE

TIPO **8M 50**

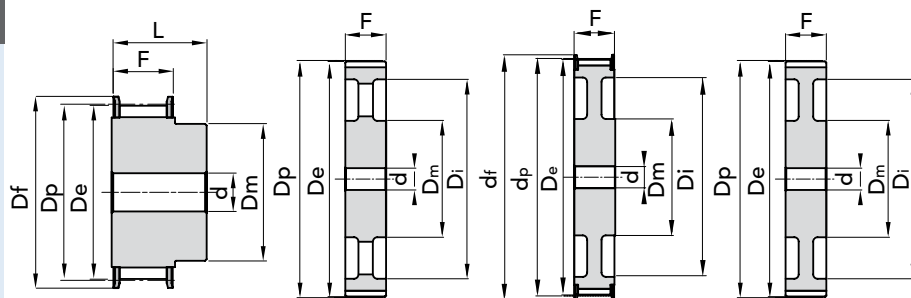

ESEC. 1F

ESEC. 5

ESEC. 6F

ESEC. 7

TIPO	CODICE	N. DENTI	ESEC.	Dp	De	Df FLANGIA	Dm MOZZO	Di	F	L	d Ø FORO	N. FLANGIA	Peso kg.
22- 8M- 50F	40450022	22	1F	56,02	54,65	60	43	-	60	70	-	53	1,10
24- 8M- 50F	40450024	24	1F	61,12	59,75	66	45	-	60	70	-	69	1,20
26- 8M- 50F	40450026	26	1F	66,21	64,85	70	48	-	60	70	-	61	1,60
28- 8M- 50F	40450028	28	1F	71,30	70,08	75	50	-	60	70	-	79	1,70
30- 8M- 50F	40450030	30	1F	76,39	75,13	82,5	55	-	60	70	-	73	2,00
32- 8M- 50F	40450032	32	1F	81,49	80,16	87	60	-	60	70	-	76	2,35
34- 8M- 50F	40450034	34	1F	86,58	85,22	91	66	-	60	70	-	66	2,80
36- 8M- 50F	40450036	36	1F	91,67	90,30	97	70	-	60	70	-	68	3,10
38- 8M- 50F	40450038	38	1F	96,77	95,39	102	75	-	60	70	-	70	3,30
40- 8M- 50F	40450040	40	1F	101,86	100,49	106	75	-	60	70	-	77	3,60
44- 8M- 50F	40450044	44	1F	112,05	110,67	120	75	-	60	70	-	75	4,40
48- 8M- 50F	40450048	48	1F	122,23	120,86	128	75	-	60	70	-	78	5,00
56- 8M- 50F	40450056	56	6F	142,60	141,23	150	90	116	60	60	18	85	5,68
64- 8M- 50F	40450064	64	6F	162,97	161,60	168	100	137	60	60	18	90	6,93
72- 8M- 50F	40450072	72	6F	183,35	181,97	192	100	158	60	60	18	97	7,95
80- 8M- 50	40450080	80	7	203,72	202,35	-	100	180	60	60	18	-	7,96
90- 8M- 50	40450090	90	7	229,18	227,81	-	100	204	60	60	18	-	9,20
112- 8M- 50	40450112	112	5	285,21	283,83	-	100	224	60	60	18	-	12,16
144- 8M- 50	40450144	144	5	366,69	365,32	-	100	336	60	60	20	-	15,68
168- 8M- 50	40450168	168	5	427,81	426,44	-	120	400	60	60	20	-	18,99
192- 8M- 50	40450192	192	5	488,92	487,55	-	130	460	60	60	20	-	21,09

MATERIALE **ACCIAIO**

MATERIALE **GHISA**



Le immagini non sono identificative del prodotto.

PULEGGE DENTATE HTD® CON FORO INIZIALE "FOSFATATE" 8M 50

# PULEGGE DENTATE HTD® CON FORO INIZIALE

PULEGGE DENTATE HTD® CON FORO INIZIALE "FOSFATE" 8M 85

FOSFATE

TIPO **8M 85**

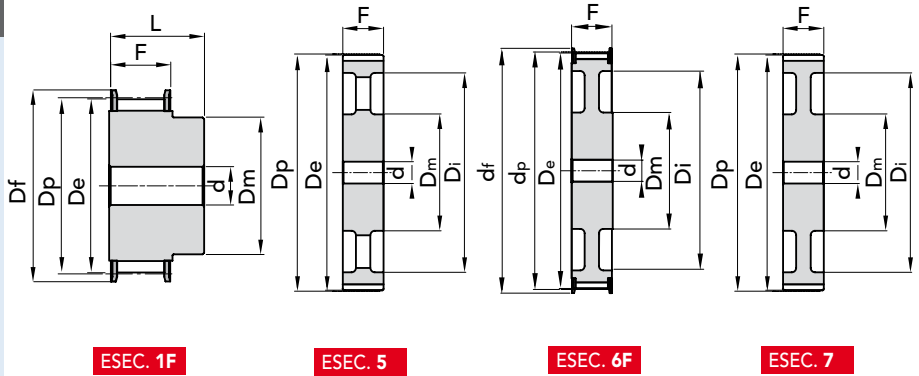

ESEC. 1F

ESEC. 5

ESEC. 6F

ESEC. 7

TIPO	CODICE	N. DENTI	ESEC.	Dp	De	Df FLANGIA	Dm MOZZO	Di	F	L	d Ø FORO	N. FLANGIA	Peso kg.
22- 8M- 85F	40485022	22	1F	56,02	54,65	60	43	-	95	105	-	53	1,60
24- 8M- 85F	40485024	24	1F	61,12	59,75	66	45	-	95	105	-	69	1,95
26- 8M- 85F	40485026	26	1F	66,21	64,85	70	48	-	95	105	-	61	2,30
28- 8M- 85F	40485028	28	1F	71,30	70,08	75	50	-	95	105	-	79	2,60
30- 8M- 85F	40485030	30	1F	76,39	75,13	82,5	55	-	95	105	-	73	3,10
32- 8M- 85F	40485032	32	1F	81,49	80,16	87	60	-	95	105	-	76	3,70
34- 8M- 85F	40485034	34	1F	86,58	85,22	91	66	-	95	105	-	66	4,00
36- 8M- 85F	40485036	36	1F	91,67	90,30	97	70	-	95	105	-	68	4,70
38- 8M- 85F	40485038	38	1F	96,77	95,39	102	75	-	95	105	-	70	5,10
40- 8M- 85F	40485040	40	1F	101,86	100,49	106	75	-	95	105	-	77	5,40
44- 8M- 85F	40485044	44	1F	112,05	110,67	120	75	-	95	105	-	75	6,70
48- 8M- 85F	40485048	48	1F	122,23	120,86	128	80	-	95	105	-	78	7,20
56- 8M- 85F	40485056	56	1F	142,60	141,23	150	90	-	95	105	20	85	11,48
64- 8M- 85F	40485064	64	6F	162,97	161,60	168	100	137	95	95	20	90	11,02
72- 8M- 85F	40485072	72	6F	183,35	181,97	192	100	158	95	95	20	97	13,45
80- 8M- 85	40485080	80	7	203,72	202,35	-	110	180	95	95	20	-	12,36
90- 8M- 85	40485090	90	7	229,18	227,81	-	110	204	95	95	20	-	14,38
112- 8M- 85	40485112	112	5	285,21	283,83	-	110	224	95	95	24	-	18,66
144- 8M- 85	40485144	144	5	366,69	365,32	-	110	336	95	95	24	-	23,00
168- 8M- 86	a richiesta	168	5	427,81	426,44	-	120	400	95	95	24	-	-
192- 8M- 87	a richiesta	192	5	488,91	487,55	-	130	460	95	95	24	-	-

MATERIALE ACCIAIO

MATERIALE GHISA



# PULEGGE DENTATE HTD® CON FORO INIZIALE

FOSFATATE

TIPO **14M 40**

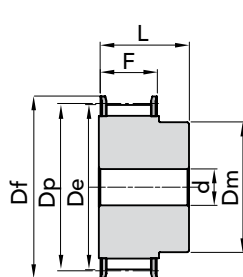

ESEC. 1F

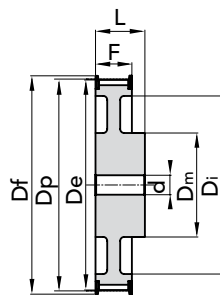

ESEC. 2F

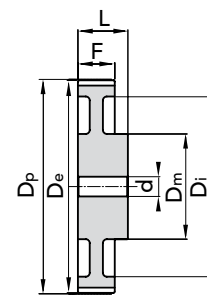

ESEC. 4

TIPO	CODICE	N. DENTI	ESEC.	Dp	De	Df FLANGIA	Dm MOZZO	Di	F	L	d Ø FORO	N. FLANGIA	Peso kg.
28-14M- 40F	40640028	28	1F	124,78	122,12	128	100	-	54	69	24	153	4,80
29-14M- 40F	40640029	29	1F	129,23	126,57	138	100	-	54	69	24	154	5,20
30-14M- 40F	40640030	30	1F	133,69	130,99	138	100	-	54	69	24	154	5,60
32-14M- 40F	40640032	32	1F	142,60	139,88	154	100	-	54	69	24	160	6,20
34-14M- 40F	40640034	34	1F	151,52	148,79	160	100	-	54	69	24	166	6,90
36-14M- 40F	40640036	36	1F	160,43	157,68	168	100	-	54	69	24	168	7,70
38-14M- 40F	40640038	38	1F	169,34	166,60	183	120	-	54	69	24	172	8,90
40-14M- 40F	40640040	40	1F	178,25	175,49	188	120	-	54	69	24	162	9,80
44-14M- 40F	40640044	44	1F	196,08	193,28	211	120	-	54	69	24	175	12,00
48-14M- 40F	40640048	48	2F	213,90	211,11	226	135	170	54	69	24	180	11,98
56-14M- 40F	40640056	56	2F	249,55	246,76	256	135	207	54	69	28	182	14,01
64-14M- 40F	40640064	64	2F	248,21	282,41	296	135	240	54	69	28	184	16,65
72-14M- 40	40640072	72	4	320,86	318,06	-	135	278	54	69	28	-	15,52
80-14M- 40	40640080	80	4	356,51	353,71	-	135	314	54	69	28	-	17,23
90-14M- 40	40640090	90	4	401,07	398,28	-	135	358	54	69	28	-	19,40
112-14M- 40	40640112	112	4	499,11	496,32	-	135	456	54	69	28	-	24,14
144-14M-40	a richiesta	144	4	641,71	638,92	-	135	600	54	69	28	-	-
168-14M-40	a richiesta	168	4	748,66	745,87	-	135	706	54	69	28	-	-
192-14M-40	a richiesta	192	4	855,62	852,82	-	135	813	54	69	28	-	-
216-14M-41	a richiesta	216	4	962,57	959,76	-	150	920	54	69	28	-	-

MATERIALE **ACCIAIO**

MATERIALE **GHISA**



Le immagini non sono identificative del prodotto.

PULEGGE DENTATE HTD® CON FORO INIZIALE "FOSFATATE" 14M 40

# PULEGGE DENTATE HTD® CON FORO INIZIALE

FOSFATE

TIPO **14M 55**

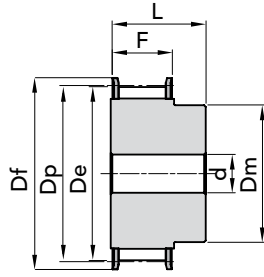

ESEC. 1F

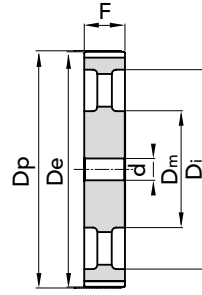

ESEC. 5

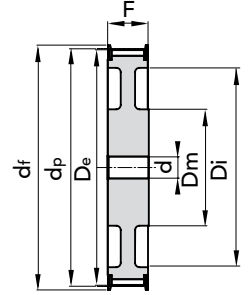

ESEC. 6F

TIPO	CODICE	N. DENTI	ESEC.	Dp	De	Df FLANGIA	Dm MOZZO	Di	F	L	d Ø FORO	N. FLANGIA	Peso kg.
28-14M- 55F	40655028	28	1F	124,78	122,12	128	100	-	70	85	24	153	5,70
29-14M- 55F	40655029	29	1F	129,23	126,57	138	100	-	70	85	24	154	6,40
30-14M- 55F	40655030	30	1F	133,69	130,99	138	100	-	70	85	24	154	7,10
32-14M- 55F	40655032	32	1F	142,60	139,88	154	100	-	70	85	24	160	7,90
34-14M- 55F	40655034	34	1F	151,52	148,79	160	100	-	70	85	24	166	9,33
36-14M- 55F	40655036	36	1F	160,43	157,68	168	100	-	70	85	24	168	10,49
38-14M- 55F	40655038	38	1F	169,34	166,60	183	120	-	70	85	24	172	12,11
39- 14M- 55F													
40-14M- 55F	40655040	40	1F	178,25	175,49	188	120	-	70	85	24	162	13
44-14M- 55F	40655044	44	1F	196,08	193,28	211	120	-	70	85	24	175	16,12
48-14M- 55F	40655048	48	6F	213,90	211,11	226	135	170	70	70	24	180	13,50
56-14M- 55F	40655056	56	6F	249,55	246,76	256	135	207	70	70	28	182	15,78
64-14M- 55F	40655064	64	6F	285,21	282,41	296	135	240	70	70	28	184	19,04
72-14M- 55	40655072	72	5	320,86	318,06	-	135	278	70	70	28	-	18,41
80-14M- 55	40655080	80	5	356,51	353,71	-	135	314	70	70	28	-	20,27
90-14M- 55	40655090	90	5	401,07	398,28	-	135	358	70	70	28	-	22,98
112-14M- 55	40655112	112	5	499,11	496,32	-	135	456	70	70	28	-	29,29
144-14M- 55	40655144	144	5	641,71	638,92	-	135	600	70	70	28	-	36,00
168-14M- 55	40655168	168	5	748,66	745,87	-	135	706	70	70	28	-	40,00
192-14M- 55	40655192	192	5	855,62	852,82	-	135	813	70	70	28	-	47,50
216-14M- 56	a richiesta	216	5	962,57	959,76	-	150	920	70	70	28	-	-

MATERIALE **ACCIAIO**

MATERIALE **GHISA**



# PULEGGE DENTATE HTD® CON FORO INIZIALE

FOSFATATE

TIPO **14M 85**

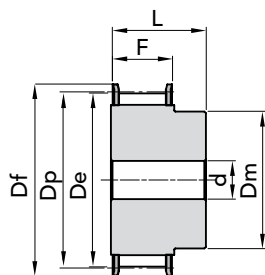

ESEC. 1F

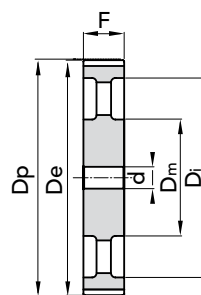

ESEC. 5

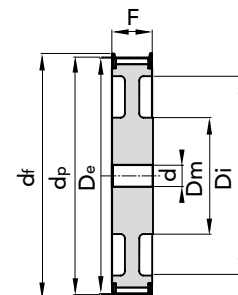

ESEC. 6F

TIPO	CODICE	N. DENTI	ESEC.	Dp	De	Df FLANGIA	Dm MOZZO	Di	F	L	d Ø FORO	N. FLANGIA	Peso kg.
28-14M- 85F	40685028	28	1F	124,78	122,12	128	100	-	102	117	-	153	8,77
29-14M- 85F	a richiesta	29	1F	129,23	126,57	138	100	-	102	117	-	154	-
30-14M- 85F	40685030	30	1F	133,69	130,99	138	100	-	102	117	-	154	9,45
32-14M- 85F	40685032	32	1F	142,60	139,88	154	100	-	102	117	-	160	10,13
34-14M- 85F	40685034	34	1F	151,52	148,79	160	100	-	102	117	-	166	11,65
36-14M- 85F	40685036	36	1F	160,43	157,68	168	100	-	102	117	-	168	14,48
38-14M- 85F	40685038	38	1F	169,34	166,60	183	120	-	102	117	-	172	16,62
40-14M- 85F	40685040	40	1F	178,25	175,49	188	135	-	102	117	-	162	18,84
44-14M- 85F	40685044	44	1F	196,08	193,28	211	135	-	102	117	-	175	23,00
48-14M- 85F	40685048	48	1F	213,90	211,11	226	150	-	102	117	-	180	27,58
56-14M- 85F	40685056	56	6F	249,55	246,76	256	150	207	102	102	32	182	24,19
64-14M- 85F	40685064	64	6F	285,21	282,41	296	150	240	102	102	32	184	28,57
72-14M- 85	40685072	72	5	320,86	318,06	-	150	278	102	102	32	-	28,26
80-14M- 85	40685080	80	5	356,51	353,71	-	150	314	102	102	32	-	31,00
90-14M- 85	40685090	90	5	401,07	398,28	-	150	358	102	102	32	-	35,00
112-14M- 85	40685112	112	5	499,11	496,32	-	150	456	102	102	32	-	43,50
144-14M- 85	40685144	144	5	641,71	638,92	-	150	600	102	102	32	-	50,00
168-14M- 85	40685168	168	5	748,66	745,87	-	150	706	102	102	32	-	63,00
192-14M- 85	40685192	192	5	855,62	852,82	-	165	813	102	102	32	-	76,00
216-14M- 86	a richiesta	216	5	962,57	959,76	-	165	920	102	102	32	-	-

MATERIALE ACCIAIO

MATERIALE GHISA



Le immagini non sono identificative del prodotto.

PULEGGE DENTATE HTD® CON FORO INIZIALE "FOSFATATE" 14M 85

# PULEGGE DENTATE HTD® CON FORO INIZIALE

PULEGGE DENTATE HTD® CON FORO INIZIALE "FOSFATATE" 14M 115

FOSFATATE

TIPO **14M 115**

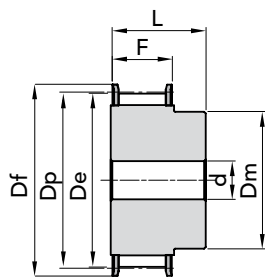

ESEC. 1F

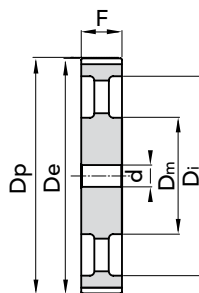

ESEC. 5

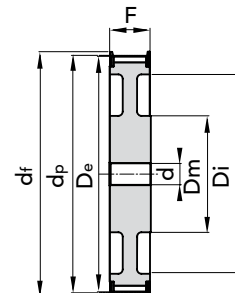

ESEC. 6F

TIPO	CODICE	N. DENTI	ESEC.	Dp	De	Df FLANGIA	Dm MOZZO	Di	F	L	d Ø FORO	N. FLANGIA	Peso kg.
28-14M- 115F	40690028	28	1F	124,78	122,12	128	100	-	133	148	-	153	11
29-14M- 115F	a richiesta	29	1F	129,23	126,57	138	100	-	133	148	-	154	-
30-14M- 115F	40690030	30	1F	133,69	130,99	138	100	-	133	148	-	154	12,52
32-14M- 115F	40690032	32	1F	142,60	139,88	154	100	-	133	148	-	160	14,48
34-14M- 115F	40690034	34	1F	151,52	148,79	160	100	-	133	148	-	166	16,45
36-14M- 115F	40690036	36	1F	160,43	157,68	168	120	-	133	148	-	168	18,99
38-14M- 115F	40690038	38	1F	169,34	166,60	183	120	-	133	148	-	172	21,31
40-14M- 115F	40690040	40	1F	178,25	175,49	188	135	-	133	148	-	162	24,04
44-14M- 115F	40690044	44	1F	196,08	193,28	211	140	-	133	148	-	175	29
48-14M- 115F	40690048	48	1F	213,90	211,11	226	150	-	133	148	-	180	35,00
56-14M- 115F	40690056	56	1F	249,55	246,76	256	150	-	133	148	-	182	48,00
64-14M- 115F	40690064	64	6F	285,21	282,41	296	150	240	133	133	32	184	36,00
72-14M- 115	40690072	72	5	320,86	318,06	-	150	278	133	133	32	-	36,00
80-14M- 115	40690080	80	5	356,51	353,71	-	150	314	133	133	32	-	40
90-14M- 115	40690090	90	5	401,07	398,28	-	150	358	133	133	32	-	45,00
112-14M- 115	40690112	112	5	499,11	496,32	-	150	456	133	133	32	-	55,50
144-14M- 115	40690144	144	5	641,71	638,92	-	150	600	133	133	32	-	71,00
168-14M- 115	40690168	168	5	748,66	745,87	-	150	706	133	133	32	-	83,00
192-14M- 115	40690192	192	5	855,62	852,82	-	165	813	133	133	32	-	96,00
216-14M- 116	a richiesta	216	5	962,57	959,76	-	165	920	133	133	32	-	-

MATERIALE ACCIAIO

MATERIALE GHISA



# PULEGGE DENTATE HTD® CON FORO INIZIALE

FOSFATATE

TIPO **14M 170**

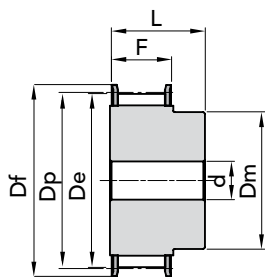

ESEC. 1F

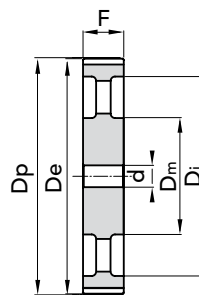

ESEC. 5

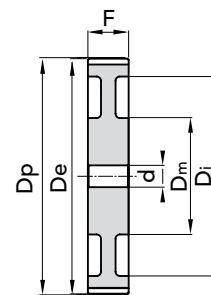

ESEC. 7

TIPO	CODICE	N. DENTI	ESEC.	Dp	De	Df FLANGIA	Dm MOZZO	Di	F	L	d Ø FORO	N. FLANGIA	Peso kg.
28-14M- 170F	40692028	28	1F	124,78	122,12	128	100	-	187	202	-	153	14,79
29-14M- 170F	a richiesta	29	1F	129,23	126,57	138	100	-	187	202	-	154	-
30-14M- 170F	40692030	30	1F	133,69	130,99	138	100	-	187	202	-	154	17,24
32-14M- 170F	40692032	32	1F	142,60	139,88	154	100	-	187	202	-	160	19,92
34-14M- 170F	40692034	34	1F	151,52	148,79	160	100	-	187	202	-	166	22,72
36-14M- 170F	40692036	36	1F	160,43	157,68	168	120	-	187	202	-	168	26,07
38-14M- 170F	40692038	38	1F	169,34	166,60	183	135	-	187	202	-	172	29,71
40-14M- 170F	40692040	40	1F	178,25	175,49	188	140	-	187	202	-	162	33,50
44-14M- 170F	a richiesta	44	1F	196,08	193,28	211	160	-	187	202	-	175	-
48-14M- 170F	a richiesta	48	1F	213,90	211,11	226	160	-	187	202	-	180	-
56-14M- 170F	a richiesta	56	1F	249,55	246,76	256	160	-	187	202	-	182	-
64-14M- 170F	a richiesta	64	1F	285,21	282,41	296	180	-	187	202	-	184	-
72-14M- 170	a richiesta	72	7	320,86	318,06	-	180	278	187	187	32	-	-
80-14M- 170	40692080	80	7	356,51	353,71	-	180	314	187	187	32	-	71,00
90-14M- 170	40692090	90	5	401,07	398,28	-	180	358	187	187	38	-	73,00
112-14M- 170	40692112	112	5	499,11	496,32	-	200	456	187	187	38	-	95,00
144-14M- 170	40692144	144	5	641,71	638,92	-	220	600	187	187	38	-	114
168-14M- 170	40692168	168	5	748,66	745,87	-	220	706	187	187	38	-	142,00
192-14M- 170	a richiesta	192	5	855,61	852,82	-	220	813	187	187	38	-	-
216-14M- 171	a richiesta	216	5	962,57	959,76	-	220	920	187	187	38	-	-

MATERIALE **ACCIAIO**

MATERIALE **GHISA**



Le immagini non sono identificative del prodotto.

PULEGGE DENTATE HTD® CON FORO INIZIALE "FOSFATATE" 14M 170