

PULEGGE DENTATE CON FORO INIZIALE

PULEGGE DENTATE CON FORO INIZIALE

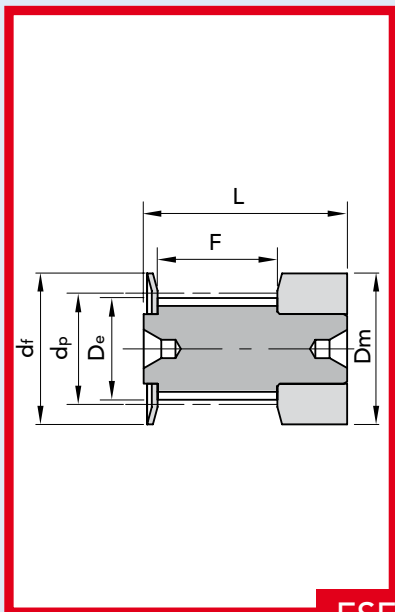

ESECUZIONE 0F

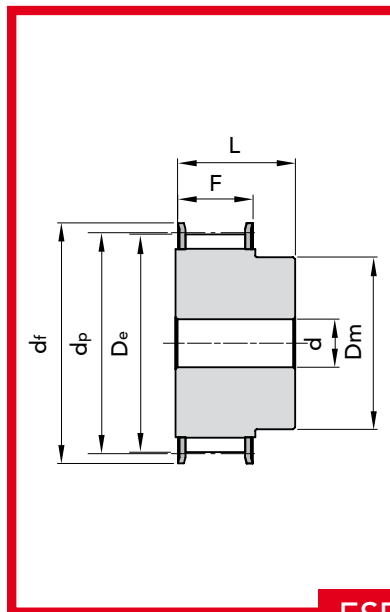

ESECUZIONE 1F

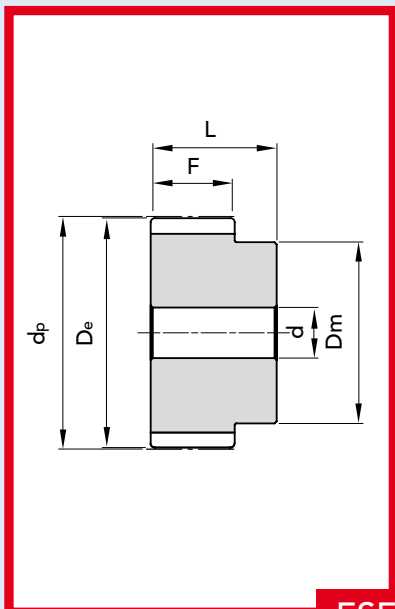

ESECUZIONE 2

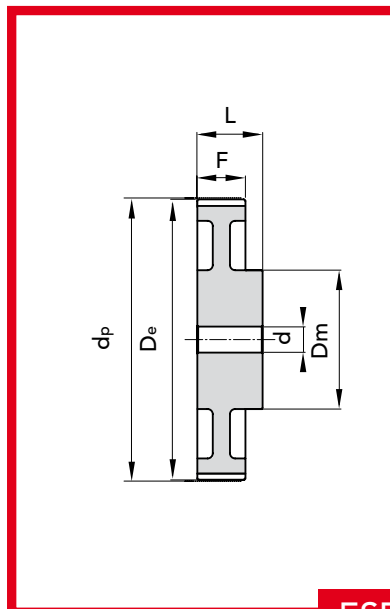

ESECUZIONE 3

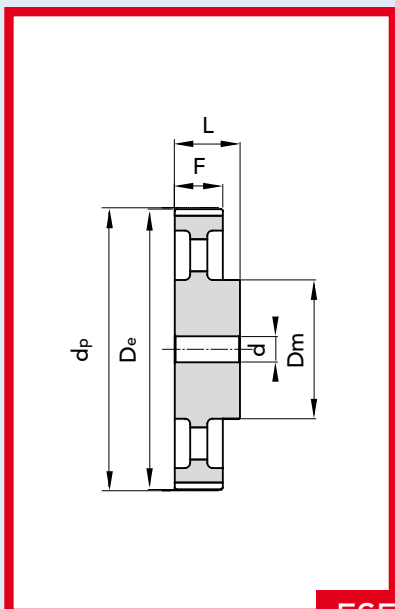

ESECUZIONE 4

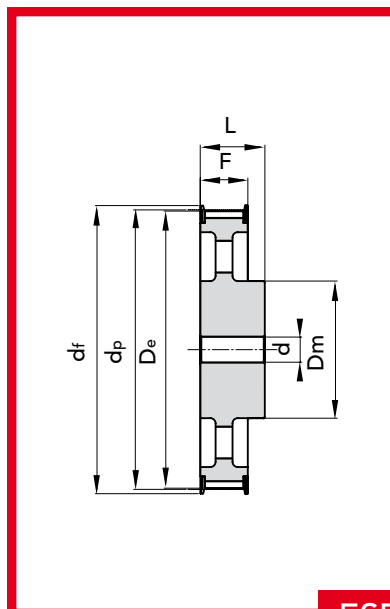

ESECUZIONE 5F

PULEGGE DENTATE CON FORO INIZIALE

PER CINGHIE POSITIVE

TIPO **L 050**

PASSO 3/8" (9.52 mm)

Dentature diverse
fornibili a richiesta

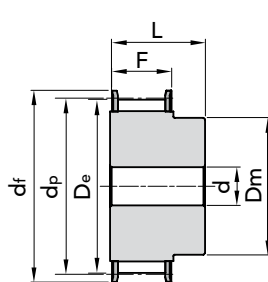

ESEC. 1F

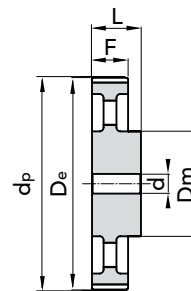

ESEC. 4

TIPO	CODICE	N. DENTI	ESEC.	Dp	De	Df FLANGIA	Dm MOZZO	F	L	d	N. FLANGIA	Peso kg.
10 L 050	42050010	10	1F	30,33	29,56	37	20	19	28	8	50	0,11
11 L 050	42050011	11	1F	33,35	32,59	37	22	19	30	8	50	0,14
12 L 050	42050012	12	1F	36,37	35,62	43	24	19	30	8	52	0,17
13 L 050	42050013	13	1F	39,41	38,65	44	28	19	30	8	83	0,21
14 L 050	42050014	14	1F	42,44	41,68	48	28	19	30	8	54	0,24
15 L 050	42050015	15	1F	45,48	44,72	51	34	19	30	8	55	0,29
16 L 050	42050016	16	1F	48,51	47,75	54	36	19	32	8	56	0,33
17 L 050	42050017	17	1F	51,54	50,78	57	36	19	32	10	57	0,38
18 L 050	42050018	18	1F	54,59	53,81	60	40	19	32	10	58	0,44
19 L 050	42050019	19	1F	57,61	56,84	64	40	19	32	10	59	0,47
20 L 050	42050020	20	1F	60,63	59,88	66	40	19	32	10	60	0,51
21 L 050	42050021	21	1F	63,68	62,91	70	45	19	32	10	61	0,6
22 L 050	42050022	22	1F	66,70	65,94	75	45	19	32	10	62	0,64
23 L 050	42050023	23	1F	69,73	68,97	79	55	19	32	10	63	0,78
24 L 050	42050024	24	1F	72,77	72,00	79	55	19	32	10	63	0,81
25 L 050	42050025	25	1F	75,80	75,04	82	58	19	32	10	64	0,89
26 L 050	42050026	26	1F	78,84	78,07	86	58	19	32	11	65	0,94
27 L 050	42050027	27	1F	81,86	81,10	86	58	19	32	11	65	0,99
28 L 050	42050028	28	1F	84,89	84,13	91	58	19	32	11	66	1,04
30 L 050	42050030	30	1F	90,96	90,20	97	70	19	32	11	68	1,17
32 L 050	42050032	32	1F	97,03	96,26	102	70	19	32	11	70	1,41
33 L 050	42050033	33	1F	100,05	99,29	106	70	19	32	11	71	1,49
34 L 050	42050034	34	1F	103,08	102,32	112	70	19	32	11	72	1,57
35 L 050	42050035	35	1F	106,12	105,35	112	70	19	32	11	72	1,62
36 L 050	42050036	36	1F	109,14	108,39	115	70	19	32	11	74	1,7
40 L 050	42050040	40	1F	121,29	120,51	128	70	19	32	11	78	2,03
42 L 050	42050042	42	1F	127,34	126,57	135	70	19	32	11	80	2,21
44 L 050	42050044	44	1F	133,4	132,64	142	70	19	32	11	81	2,38
45 L 050	42050045	45	1F	136,44	135,67	142	70	19	32	11	81	2,48
48 L 050	42050048	48	1F	145,54	144,77	150	70	19	32	11	85	2,78
50 L 050	42050050	50	4	151,6	150,83	-	70	19	32	14	-	1,74
52 L 050	42050052	52	4	157,66	156,9	-	70	19	32	14	-	1,8
56 L 050	42050056	56	4	169,79	169,02	-	70	19	32	14	-	1,87
57 L 050	42050057	57	4	172,82	172,06	-	70	19	32	14	-	1,88
60 L 050	42050060	60	4	181,92	181,15	-	75	19	42	14	-	2,41
72 L 050	42050072	72	4	218,29	217,53	-	75	19,0	42	14	-	2,82
84 L 050	42050084	84	4	254,69	253,92	-	75	19,0	42	14	-	3,08
96 L 050	42050096	96	4	291,06	290,3	-	75	19,0	42	14	-	3,42

MATERIALE **ACCIAIO**

C 45

MATERIALE **GHISA**

PULEGGE DENTATE CON FORO INIZIALE

PER CINGHIE POSITIVE

TIPO **L 075**

PASSO 3/8" (9.52 mm)

Dentature diverse
fornibili a richiesta

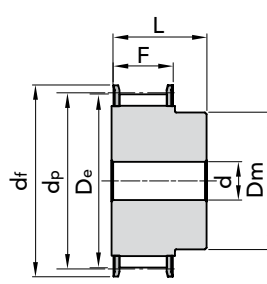

ESEC. 1F

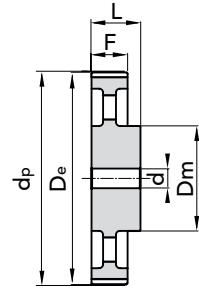

ESEC. 4

TIPO	CODICE	N. DENTI	ESEC.	Dp	De	Df FLANGIA	Dm MOZZO	F	L	d	N. FLANGIA	Peso kg.
10 L 075	42075010	10	1F	30,33	29,56	37	20	25,4	38	8	50	0,14
11 L 075	42075011	11	1F	33,35	32,59	37	22	25,4	38	8	50	0,18
12 L 075	42075012	12	1F	36,37	35,62	43	24	25,4	38	8	52	0,22
13 L 075	42075013	13	1F	39,41	38,65	44	28	25,4	38	8	83	0,26
14 L 075	42075014	14	1F	42,44	41,68	48	28	25,4	38	11	54	0,3
15 L 075	42075015	15	1F	45,48	44,72	51	34	25,4	38	11	55	0,37
16 L 075	42075016	16	1F	48,51	47,75	54	36	25,4	38	11	56	0,43
17 L 075	42075017	17	1F	51,54	50,78	57	36	25,4	38	11	57	0,46
18 L 075	42075018	18	1F	54,59	53,81	60	40	25,4	38	11	58	0,54
19 L 075	42075019	19	1F	57,61	56,84	64	40	25,4	38	11	59	0,58
20 L 075	42075020	20	1F	60,63	59,88	66	40	25,4	38	11	60	0,64
21 L 075	42075021	21	1F	63,68	62,91	70	45	25,4	38	11	61	0,71
22 L 075	42075022	22	1F	66,70	65,94	75	45	25,4	38	11	62	0,79
23 L 075	42075023	23	1F	69,73	68,97	79	55	25,4	38	11	63	0,94
24 L 075	42075024	24	1F	72,77	72,00	79	55	25,4	38	11	63	1
25 L 075	42075025	25	1F	75,80	75,04	82	58	25,4	38	11	64	1,1
26 L 075	42075026	26	1F	78,84	78,07	86	58	25,4	38	11	65	1,16
27 L 075	42075027	27	1F	81,86	81,10	86	58	25,4	38	11	65	1,22
28 L 075	42075028	28	1F	84,89	84,13	91	58	25,4	38	11	66	1,3
30 L 075	42075030	30	1F	90,96	90,20	97	70	25,4	38	11	68	1,47
32 L 075	42075032	32	1F	97,03	96,26	102	70	25,4	38	11	70	1,75
33 L 075	42075033	33	1F	100,05	99,29	106	70	25,4	38	11	71	1,85
34 L 075	42075034	34	1F	103,08	102,32	112	70	25,4	38	11	72	1,93
35 L 075	42075035	35	1F	106,12	105,35	112	70	25,4	38	11	72	2,03
36 L 075	42075036	36	1F	109,14	108,39	115	70	25,4	38	11	74	2,14
40 L 075	42075040	40	1F	121,29	120,51	128	70	25,4	38	11	78	2,56
42 L 075	42075042	42	1F	127,34	126,57	135	70	25,4	38	11	80	2,81
44 L 075	42075044	44	1F	133,4	132,64	142	70	25,4	38	11	81	3,02
45 L 075	42075045	45	1F	136,44	135,67	142	70	25,4	38	11	81	3,16
48 L 075	42075048	48	1F	145,54	144,77	150	70	25,4	38	11	85	3,57
50 L 075	42075050	50	4	151,6	150,83	-	70	25,4	38	14	-	2,1
52 L 075	42075052	52	4	157,66	156,9	-	70	25,4	38	14	-	2,13
56 L 075	42075056	56	4	169,79	169,02	-	70	25,4	38	14	-	2,27
57 L 075	42075057	57	4	172,82	172,06	-	70	25,4	38	14	-	2,28
60 L 075	42075060	60	4	181,92	181,15	-	75	25,4	45	14	-	2,7
72 L 075	42075072	72	4	218,29	217,53	-	75	25,4	45	14	-	3,19
84 L 075	42075084	84	4	254,69	253,92	-	75	25,4	45	14	-	3,64
96 L 075	42075096	96	4	291,06	290,3	-	75	25,4	45	14	-	4,04

MATERIALE **ACCIAIO**
C 45

MATERIALE **GHISA**



PULEGGE DENTATE CON FORO INIZIALE

PER CINGHIE POSITIVE

TIPO **L 100**

PASSO 3/8" (9.52 mm)

Dentature diverse
fornibili a richiesta

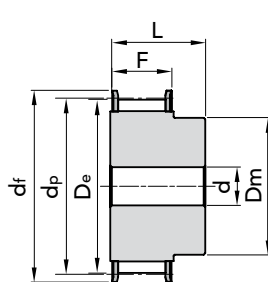

ESEC. 1F

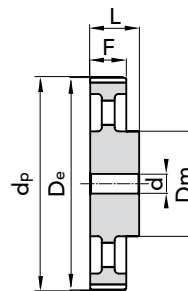

ESEC. 4

TIPO	CODICE	N. DENTI	ESEC.	Dp	De	Df FLANGIA	Dm MOZZO	F	L	d	N. FLANGIA	Peso kg.
10 L 100	42100010	10	1F	30,33	29,56	37	20	31,8	45	8	50	0,17
11 L 100	42100011	11	1F	33,35	32,59	37	22	31,8	45	8	50	0,22
12 L 100	42100012	12	1F	36,37	35,62	43	24	31,8	45	8	52	0,26
13 L 100	42100013	13	1F	39,41	38,65	44	28	31,8	45	8	83	0,32
14 L 100	42100014	14	1F	42,44	41,68	48	28	31,8	45	11	54	0,35
15 L 100	42100015	15	1F	45,48	44,72	51	34	31,8	45	11	55	0,43
16 L 100	42100016	16	1F	48,51	47,75	54	36	31,8	45	11	56	0,5
17 L 100	42100017	17	1F	51,54	50,78	57	36	31,8	45	11	57	0,56
18 L 100	42100018	18	1F	54,59	53,81	60	40	31,8	45	11	58	0,64
19 L 100	42100019	19	1F	57,61	56,84	64	40	31,8	45	11	59	0,7
20 L 100	42100020	20	1F	60,63	59,88	66	40	31,8	45	11	60	0,77
21 L 100	42100021	21	1F	63,68	62,91	70	45	31,8	45	11	61	0,88
22 L 100	42100022	22	1F	66,70	65,94	75	45	31,8	45	11	62	0,95
23 L 100	42100023	23	1F	69,73	68,97	79	55	31,8	45	11	63	1,11
24 L 100	42100024	24	1F	72,77	72,00	79	55	31,8	45	11	63	1,18
25 L 100	42100025	25	1F	75,80	75,04	82	58	31,8	45	11	64	1,3
26 L 100	42100026	26	1F	78,84	78,07	86	58	31,8	45	11	65	1,4
27 L 100	42100027	27	1F	81,86	81,10	86	58	31,8	45	11	65	1,47
28 L 100	42100028	28	1F	84,89	84,13	91	58	31,8	45	11	66	1,58
30 L 100	42100030	30	1F	90,96	90,20	97	70	31,8	45	11	68	1,78
32 L 100	42100032	32	1F	97,03	96,26	102	70	31,8	45	11	70	2,11
33 L 100	42100033	33	1F	100,05	99,29	106	70	31,8	45	11	71	2,23
34 L 100	42100034	34	1F	103,08	102,32	112	70	31,8	45	11	72	2,39
35 L 100	42100035	35	1F	106,12	105,35	112	70	31,8	45	11	72	2,45
36 L 100	42100036	36	1F	109,14	108,39	115	70	31,8	45	11	74	2,59
40 L 100	42100040	40	1F	121,29	120,51	128	70	31,8	45	11	78	3,13
42 L 100	42100042	42	1F	127,34	126,57	135	70	31,8	45	11	80	3,43
44 L 100	42100044	44	1F	133,4	132,64	142	70	31,8	45	11	81	3,72
45 L 100	42100045	45	1F	136,44	135,67	142	70	31,8	45	11	81	3,89
48 L 100	42100048	48	1F	145,54	144,77	150	70	31,8	45	11	85	4,38
50 L 100	42100050	50	4	151,6	150,83	-	70	31,8	45	14	-	2,41
52 L 100	42100052	52	4	157,66	156,9	-	70	31,8	45	14	-	2,55
56 L 100	42100056	56	4	169,79	169,02	-	70	31,8	45	14	-	2,65
57 L 100	42100057	57	4	172,82	172,06	-	70	31,8	45	14	-	2,71
60 L 100	42100060	60	4	181,92	181,15	-	75	31,8	45	14	-	3,11
72 L 100	42100072	72	4	218,29	217,53	-	75	31,8	45	14	-	3,65
84 L 100	42100084	84	4	254,69	253,92	-	75	31,8	45	14	-	4,12
96 L 100	42100096	96	4	291,06	290,3	-	75	31,8	45	14	-	4,6

MATERIALE **ACCIAIO**

C 45

MATERIALE **GHISA**



Le immagini non sono identificative del prodotto.

PULEGGE DENTATE CON FORO INIZIALE TIPO L 100