

applicazioni piedi e staffaggi cava 8

Portate piedi snodati antivibranti

Piede	D	M	Portata Kg.	Peso (g)	codice
D=40 M8x75	40	8	500	60	07PI08.008075.D40
D=40 M10x75	40	10	500	66	07PI08.010075.D40
D=40 M12x75	40	12	500	85	07PI08.012075.D40
D=50 M8x75	50	8	500	64	07PI08.008075.D50
D=50 M10x75	50	10	500	78	07PI08.010075.D50
D=50 M12x75	50	12	500	91	07PI08.012075.D50
D=80 M8x70	80	8	600	111	07PI08.008070.D80
D=80 M10x70	80	10	600	125	07PI08.010070.D80
D=80 M12x70	80	12	600	138	07PI08.012070.D80
D=80 M12x100	80	12	600	217	07PI08.012100.D80
D=80 M16x100	80	16	800	364	07PI08.016100.D80
D=100 M16x112	100	16	1000	389	07PI08.016112.D100
D=100 M16x135	100	16	1000	389	07PI08.016135.D100

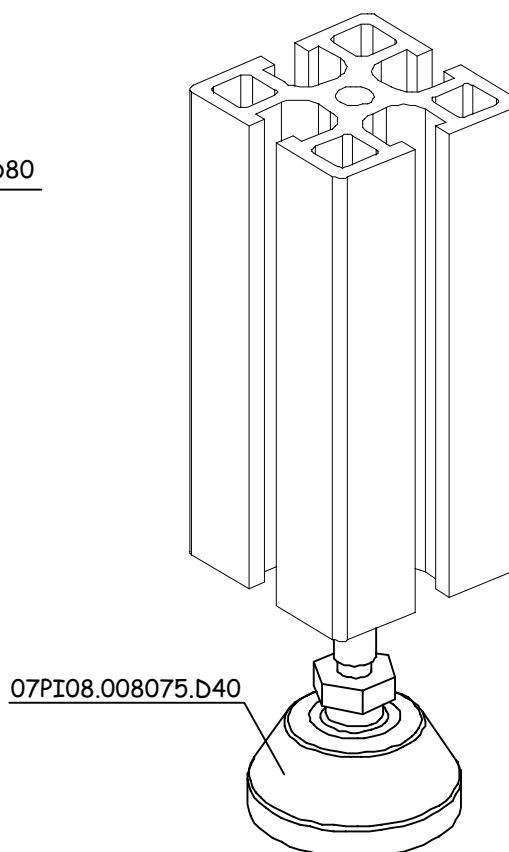
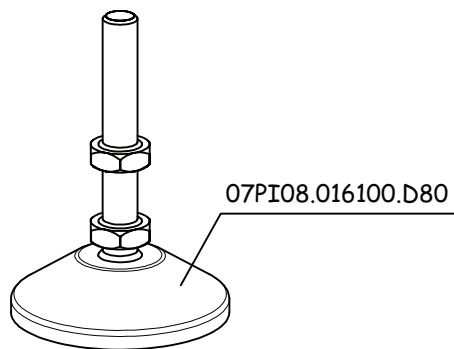

02.10.02

applicazioni piedi e staffaggi cava 8

Portata piedi snodati antiv. con fori di fissaggio a terra

piede	D	M	Portata Kg.	Peso (g)	codice
D=80 M8x70	80	8	600	118	07PI08.008070.D80F
D=80 M10x70	80	10	600	132	07PI08.010070.D80F
D=80 M12x70	80	12	600	145	07PI08.012070.D80F
D=80 M12x100	80	12	600	160	07PI08.012100.D80F
D=80 M16x100	80	16	800	224	07PI08.016100.D80F
D=100 M16x112	100	16	1000	373	07PI08.016112.D100F
D=100 M16x135	100	16	1000	398	07PI08.016135.D100F

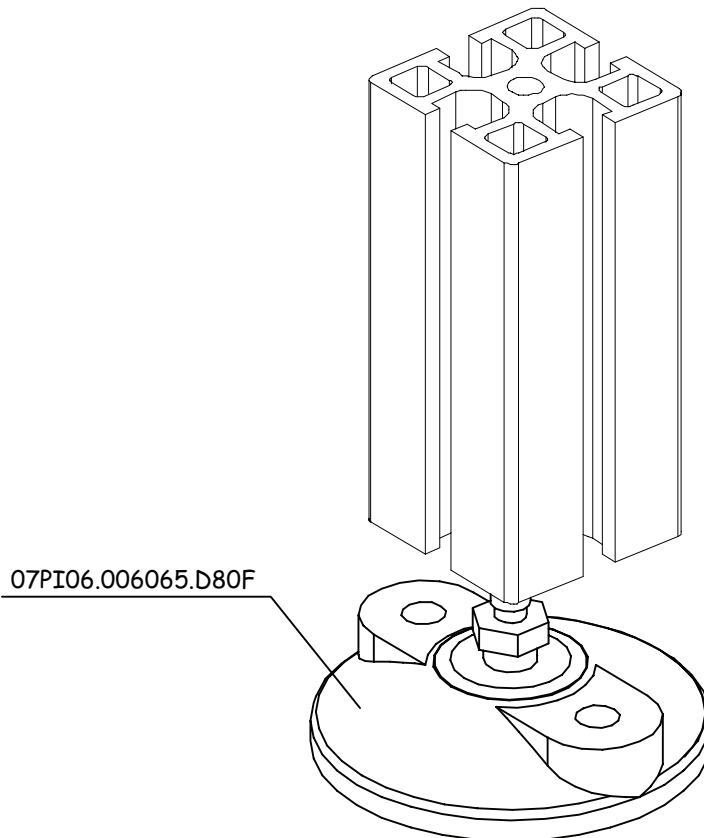

02.10.02

applicazioni piedi e staffaggi cava 8

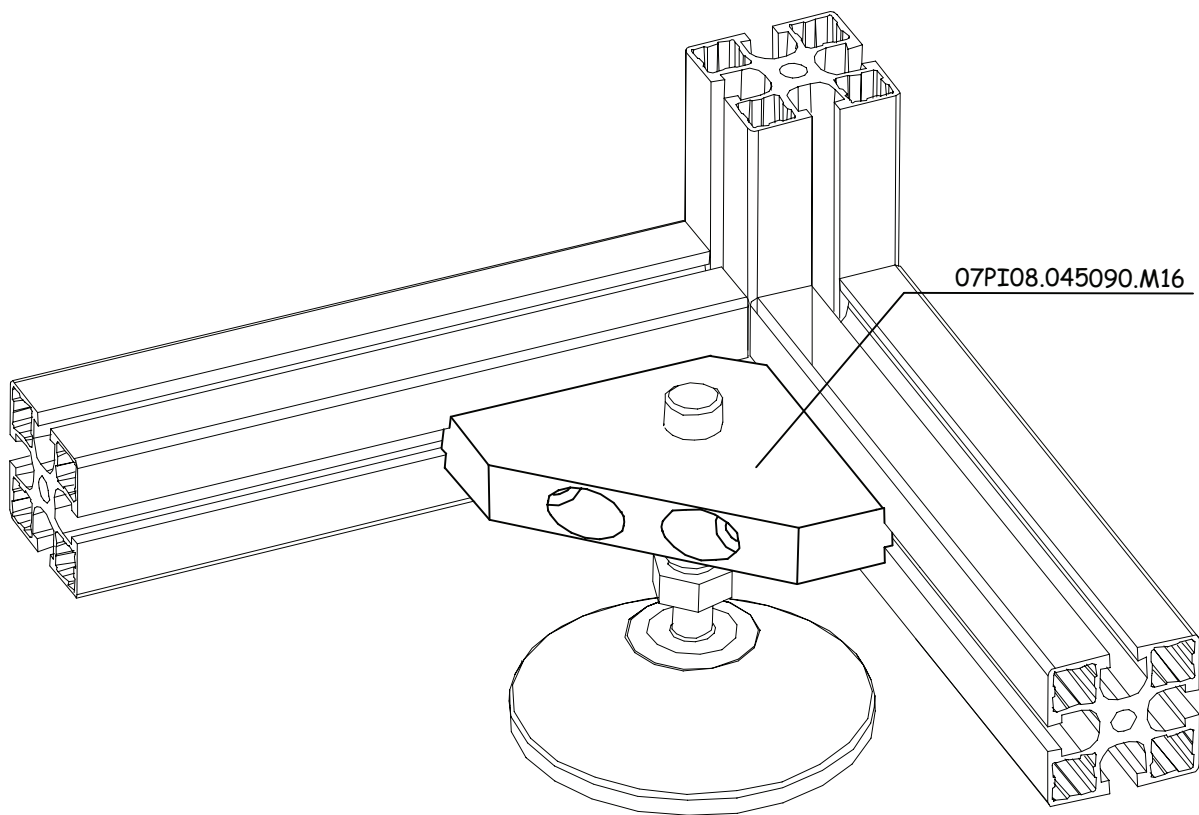
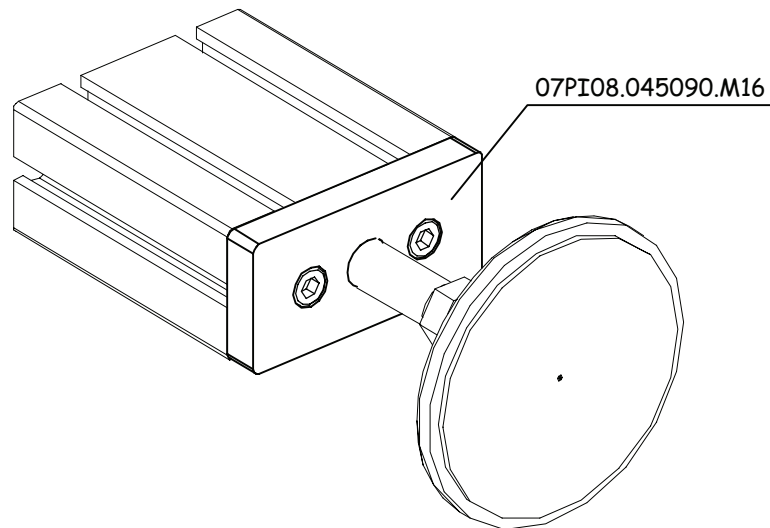

19.02.03

07PI08-03.0a

applicazioni piedi e staffaggi cava 8

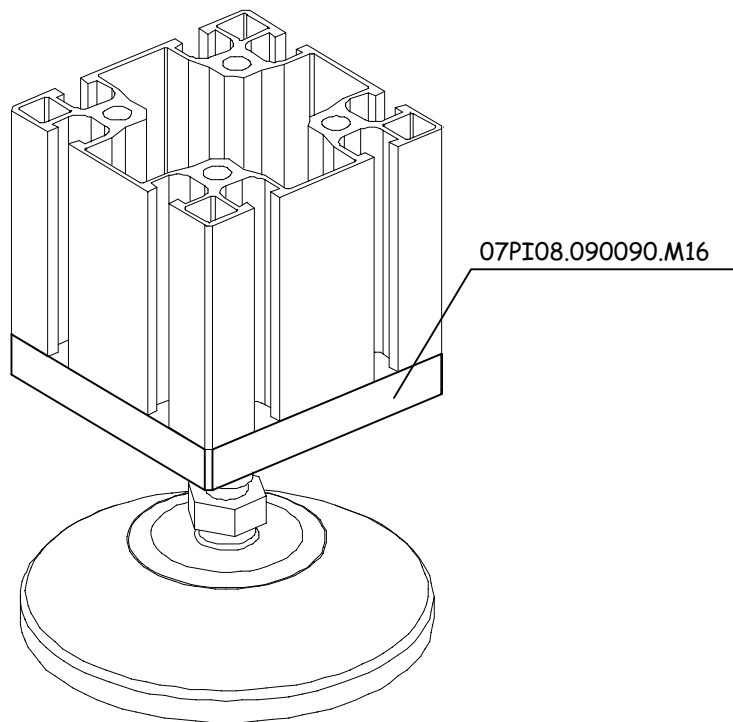

02.10.02

07PI08-04.0a

applicazioni piedi e staffaggi cava 8

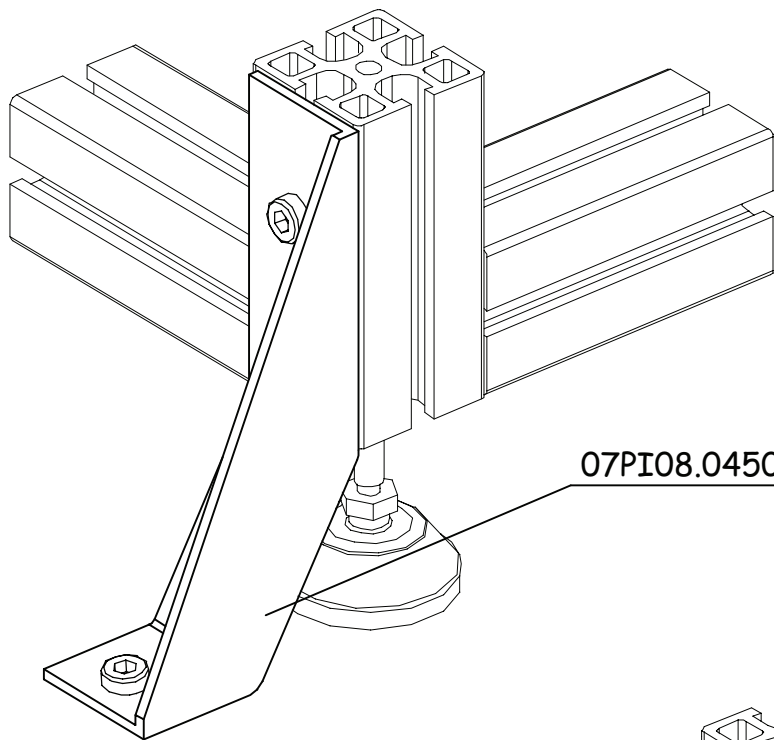

07PI08.045045.H150S

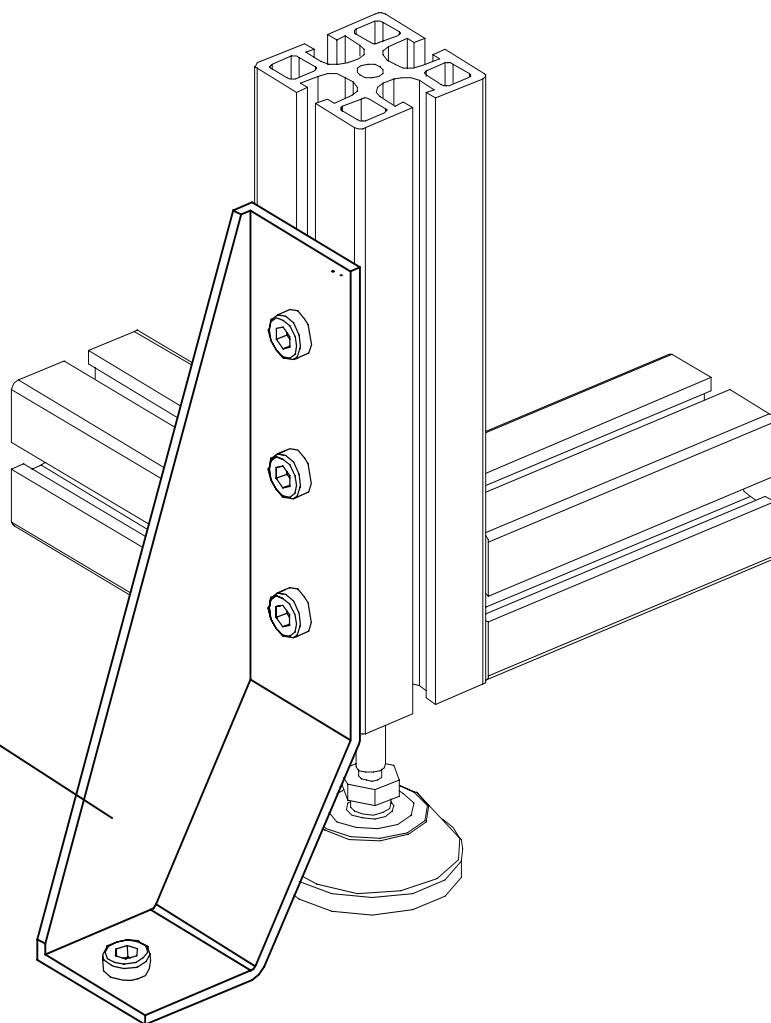

07PI08.045045.H200S

02.10.02

07PI08-05.0a

applicazioni piedi e staffaggi cava 8

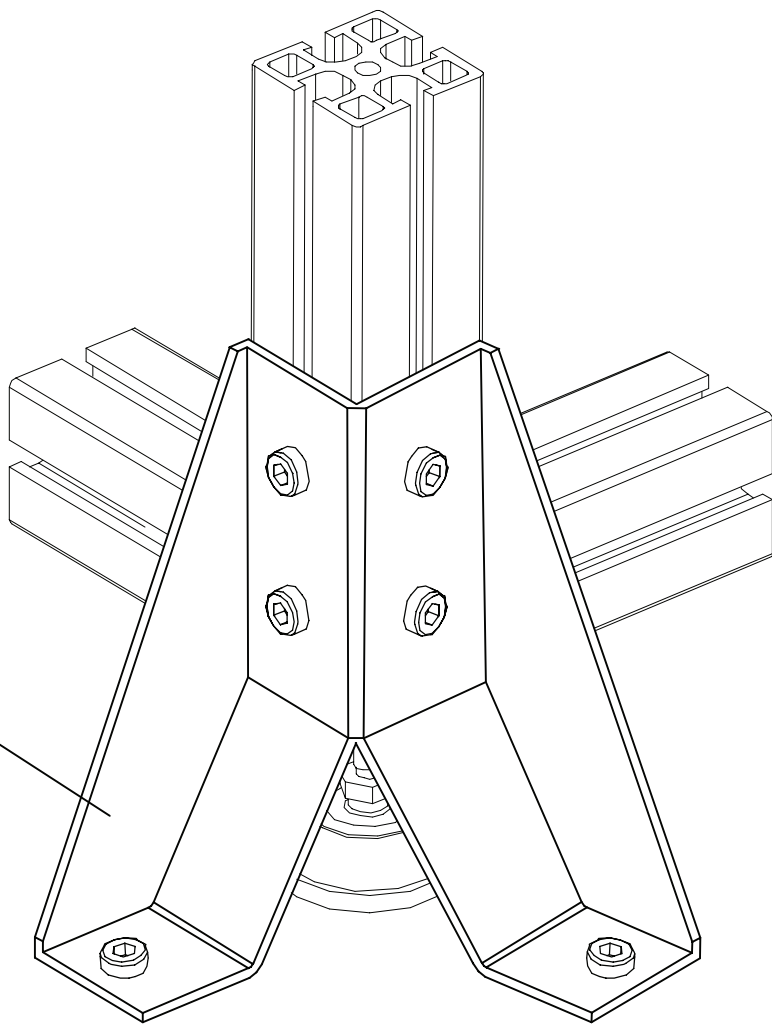

07PI08.045045.H150D

02.10.02

07PI08-05.1a

applicazioni piedi e staffaggi cava 8

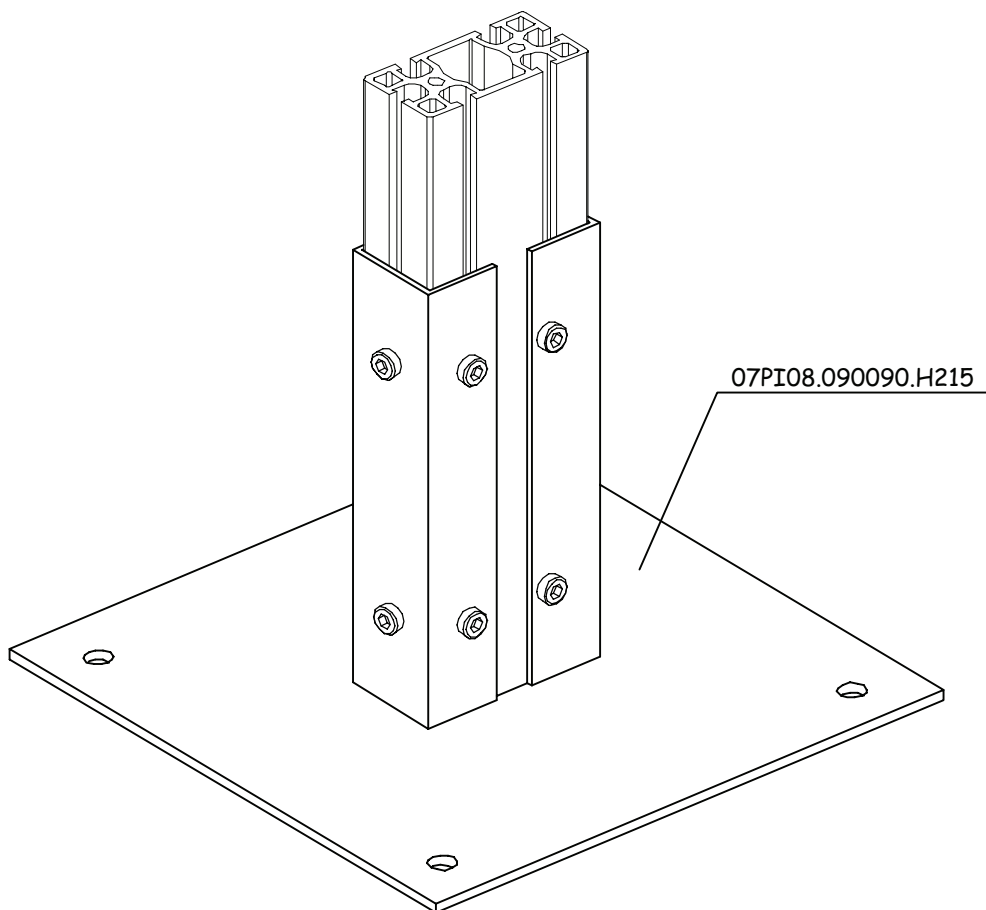
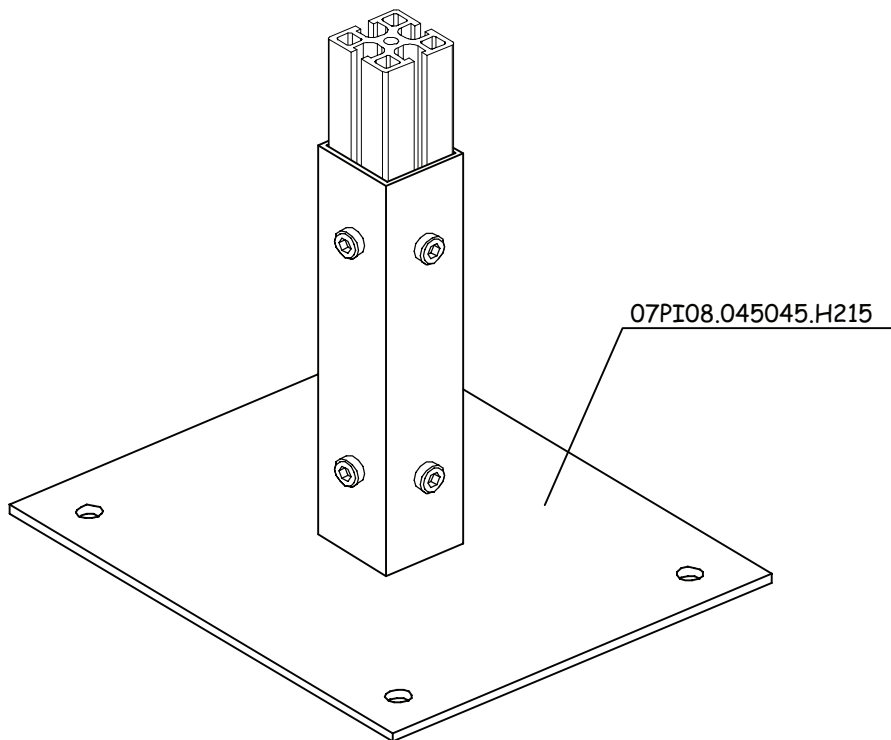

02.10.02

07PI08-06.0a

applicazioni piedi e staffaggi cava 8

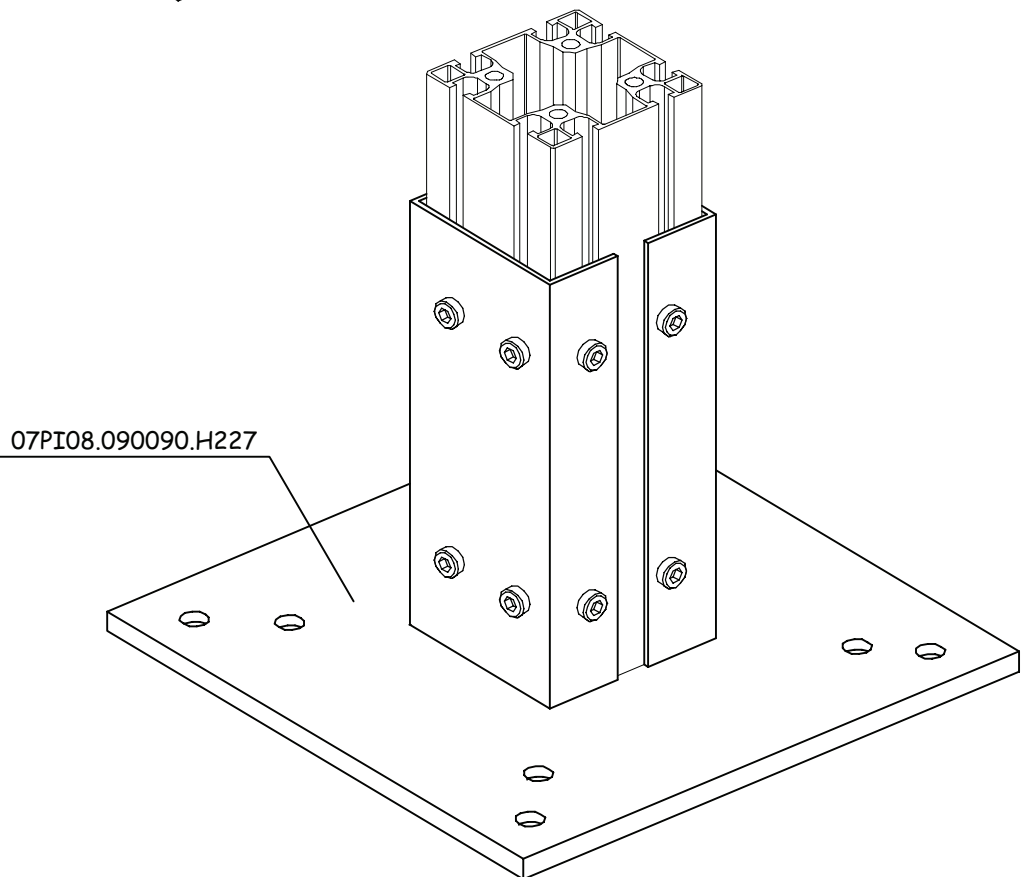
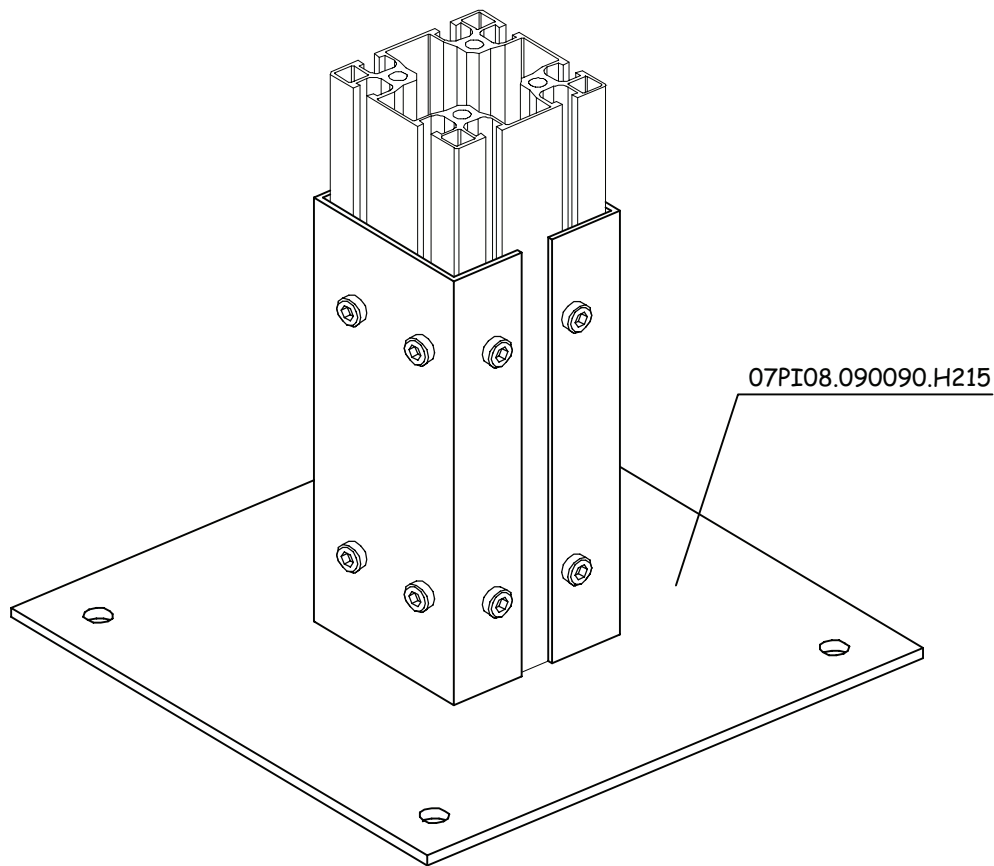

02.10.02

applicazioni piedi e staffaggi cava 8

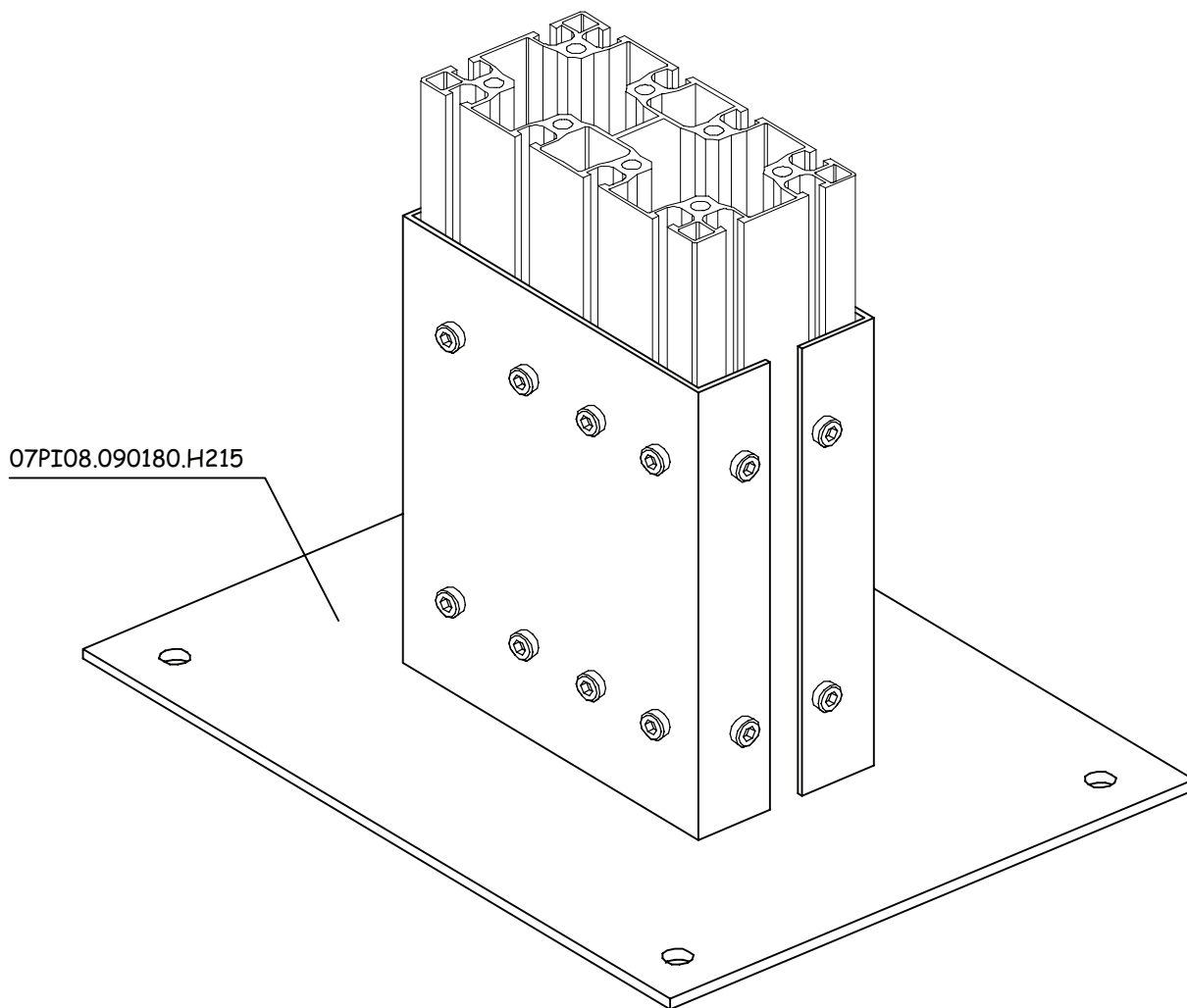

07PI08.090180.H215

02.10.02

07PI08-08.0a